



## TOWN OF APPLE VALLEY TOWN COUNCIL STAFF REPORT

---

**To:** Honorable Mayor and Town Council      **Date:** July 10, 2018  
**From:** Lori Lamson, Assistant Town Manager      **Item No:** 2  
                 Planning Department  
**Subject:** VERIZON AT MENDEL PARK SITE AGREEMENT  
**T.M. Approval:** \_\_\_\_\_      **Budgeted Item:**  Yes  No  N/A

---

### RECOMMENDED ACTION:

Approve the attached Cell Site Lease Agreement between Los Angeles SMSA LP (dba Verizon Wireless) (“Licensee”) and the Town of Apple Valley (“Licensor”) establishing the terms and conditions applicable to the installation and construction of a Los Angeles SMSA LP facility with a two (2)-carrier eucalyptus designed telecommunication facility at Mendel Park.

### SUMMARY:

The Town Council directed staff to market Town-owned properties to telecommunication service providers for the purpose of generating additional revenue to the Town and improving cellular phone service in the Town where appropriate. The lease agreement, if approved, will permit the construction of a sixty (60)-foot, two carrier wireless telecommunication tower designed as a eucalyptus tree. The tower will be situated adjacent to the parking area in Mendel Park and will include a 240 square foot CMU block wall equipment enclosure within a 440 square-foot lease area. The Planning Commission approved this facility under Conditional Use Permit No. 2017-006 and Deviation No. 2018-003 on May 16, 2018. The Town Council upheld the Planning Commission decision on June 26, 2018 on appeal.

The Agreement is similar to previously approved agreements. It includes an initial term of five (5) years and five (5) renewal, five (5) year terms with several negotiated terms that include:

- The initial annual lease rate of \$20,400 (\$1,700/mo.) and contains an annual (2%) increase. Licensee can bring a co-locating carrier onto the site, however,

any sub-lessee must enter into a separate ground lease with the Town, which will be negotiated and approved by the Town Council at that time.

Based upon the foregoing, staff recommends adoption of the form motion.

**FISCAL IMPACT:**

This Agreement will generate a minimum of \$1,700 per month (\$20,400 annually). The monthly lease rate will increase in value by 2% per year.

**ATTACHMENTS:**

1. Site Lease Agreement
2. Site Plan and Elevation Drawings

{THIS PAGE INTENTIONALLY LEFT BLANK}

**WIRELESS COMMUNICATIONS FACILITY SITE LEASE AGREEMENT  
(VERIZON - MENDEL PARK)**

THIS WIRELESS COMMUNICATIONS FACILITY SITE LEASE AGREEMENT (“Agreement”), dated as of \_\_\_\_\_, 2018 (“Effective Date”), is entered into by **TOWN OF APPLE VALLEY, CA**, a municipal corporation, having a mailing address of 14955 Dale Evans Parkway, Apple Valley, CA 92307, (hereinafter referred to as “Landlord”) and **Los Angeles SMSA Limited Partnership, dba Verizon Wireless**, with its principal offices located at One Verizon Way, Mail Stop 4AW100, Basking Ridge, New Jersey 07920 (telephone number 866-862-4404) (hereinafter referred to as “Tenant”). Landlord and Tenant may be collectively referred to as the “Parties”.

WHEREAS, Landlord is the record owner of a piece of real property located in San Bernardino County, California with Assessor’s Parcel Numbers 3080-104-06, commonly known as Mendel Park, with the legal description set forth in Exhibit “A” attached hereto (the entirety of Landlord’s property is referred to hereinafter as the “Property”) on which Landlord has constructed and operates and maintains a public park and associated improvements (“Mendel Park”); and

WHEREAS, Tenant desires to utilize a portion of the Property for the construction, installation, operation and maintenance of a wireless communications facility and associated improvements and Landlord is willing to grant such use to Tenant upon the terms and conditions of this Agreement.

NOW THEREFORE, the parties agree as follows:

**1. LEASE OF PREMISES**

Subject to the following terms and conditions, Landlord hereby leases to Tenant a certain portion of the Property being described as: (i) an approximately four hundred (400) square foot ground area for installation, operation and maintenance of Tenant’s Communications Facility (as defined in Section 2(b) below (the “Land Space”). Further, Landlord hereby grants to Tenant the non-exclusive licenses (the “Rights of Way”): (a) for ingress and egress, seven (7) days a week twenty four (24) hours a day, on foot or motor vehicle, including trucks over or along an existing asphalt driveway and parking lot on the Property, and including space for temporarily parking one vehicle on the existing asphalt driveway during technician visits; and (b) for the installation and maintenance of utility wires, cables, conduits, and pipes under one or more rights of way from the edge of the Property approximately twelve (12) feet across the Property to the Land Space. The said Land Space and Rights of Way (hereinafter collectively referred to as the “Premises”) are substantially as described and depicted herein in Exhibit “A” attached hereto and made a part hereof.

**2. PERMITTED USE**

(a) Tenant shall, at its sole cost and expense: (i) prepare the Premises for use by Tenant pursuant to this Agreement; and (ii) design, procure, construct, and maintain a 60 foot monopole-eucalyptus on the Premises, in accordance with the design described and depicted on

attached Exhibit "B" (and subject only to such modifications as may be approved in accordance with this Agreement and the terms and conditions of the Governmental Approvals as defined herein). The monopole-eucalyptus shall remain the property of Tenant. Upon termination or expiration of the Agreement, the monopole-eucalyptus monopole shall be removed by Tenant in accordance with Section 13.

(b) Tenant may use the Premises for the transmission and reception of communications signals licensed to Tenant by the Federal Communications Commission, and for the installation, construction, maintenance, operation, repair and like-for-like replacement of its communications fixtures and related equipment, cables, accessories and improvements as specified in Exhibit "B" hereto, comprising the monopole-eucalyptus described in (a) above, up to twelve (12) panel antennas attached to the monopole-eucalyptus, and other equipment and appurtenances located within the Premises and necessary to the successful and secure use of the Premises all as substantially described and depicted herein in Exhibit "B" attached hereto and made a part hereof (collectively, the "Communication Facility"), as well as the right to test, survey and review title on the Property (collectively, the "Permitted Use"). Notwithstanding the foregoing, Landlord, at no extra cost or expense, shall have the right of aerial access to the Land Space for the purpose of reasonably trimming and maintaining any trees that encroach over the Land Space, provided that this does not interfere with or adversely affect Tenant's Permitted Use as described herein.

(c) Landlord's execution of this Agreement will signify Landlord's approval of Exhibit "B". Prior to zoning submittal, Landlord shall have the right to review any modification to the approved Communication Facility. Tenant's actual construction may not vary from such plans without the prior written consent of the Landlord, Landlord's consent not to be unreasonably withheld, conditioned or delayed.

(d) Tenant's rights to use the Premises hereunder are contingent upon Tenant obtaining and complying with, and Tenant hereby agrees to comply at its sole cost and expense with the Governmental Approvals and all applicable laws, rules, statutes and regulations, relating to its use of the Communication Facility on the Premises. Tenant will be allowed to make such alterations to the Premises subject to Landlord's approval, in order to insure that Tenant's Communication Facility complies with all applicable federal, state or local laws, rules or regulations. Tenant has no right to supplement, upgrade, or expand the equipment, increase the number of antennas or relocate the Communication Facility within the Premises ("Modifications") at any time during the term of this Agreement except with the prior written approval of Landlord which approval will not be unreasonably withheld, conditioned, or delayed. The Modifications submittal process shall include the Tenant submitting (1) set of engineered drawings to the Landlord for review. The Landlord shall have sixty (60) days from time of receipt of the engineered drawings to approve or deny the proposed Modifications or the Modifications will be deemed approved. Landlord's prior written approval shall not be required for "Like-Kind Modifications". As used herein "Like-Kind Modifications" shall mean any upgrades or replacements of "like-kind" equipment which are comparable in dimension and weight and aesthetics or which are wholly contained within Tenant's equipment shelter and/or cabinets already shown on Exhibit B. All alterations, Modifications, construction and installation work in connection with the Communications Facility shall be performed at Tenant's sole cost and expense and in a good and workmanlike manner in accordance with all applicable rules, regulations and codes. Title to the Communications Facility and any equipment placed on the Premises by Tenant shall be held by the Tenant.

(e) Tenant acknowledges that the primary purpose of the Property is for the Landlord's operation of Mendel Park to provide a public recreation area and conducting the business of the Landlord, and Tenant agrees that at no time shall the Tenant's use of the Premises or its Communication Facility interfere with the Landlord's operation of Mendel Park on the Property, or the use or enjoyment of the Property by Landlord's invitees or other lessees or tenants. If Landlord reasonably determines that Tenant is interfering with such use, Landlord shall notify Tenant and Tenant shall cease such interference within forty eight (48) hours of notice, or such longer period if additional time is required but in no event longer than seven (7) days. In case of an emergency, Landlord may take steps to eliminate such interference without prior notice to Tenant and Tenant shall reimburse Landlord for all reasonable costs incurred to eliminate such interference.

(f) Tenant shall have the right to enter the Premises for non-intrusive testing activities upon full execution of this Agreement. Intrusive testing shall require the prior written consent of Landlord, not to be unreasonably withheld. Under no circumstances shall the Premises be used as a dwelling unit.

### **3. TERM AND RENT**

(a) This Agreement shall be effective as of the Effective Date, provided, however, the initial term ("Initial Term") shall be for five (5) years and shall commence on the Commencement Date (as hereinafter defined) at which time rental payments shall commence and be due at a total annual rental of Twenty Thousand Four Hundred Dollars (\$20,400.00) to be paid in equal monthly installments on the first day of the month, in advance, to Landlord. The first rent payment shall be due within ninety (90) days of the Commencement Date. The Commencement Date shall be the first day of the month after Tenant commences installation of the equipment on the Premises. The parties shall confirm in writing the Commencement Date.

(b) Rent shall be due in advance on the first day of each calendar month and will be delinquent if not paid on or before the 5<sup>th</sup> day of each calendar month of the term. If any payment due from Tenant is not received by Landlord within fifteen (15) days of written notice of nonpayment from Landlord to Tenant, Tenant shall pay to Landlord an additional sum of ten percent (10%) of the overdue payment as a late charge. The parties agree that this late charge represents a fair and reasonable estimate of the administrative costs that Landlord will incur by reason of a late payment by Tenant. Acceptance of any late payment charge shall not constitute a waiver from exercising any of the other rights and remedies available to Landlord under this Agreement, at law or in equity, including, but not limited to, any interest charges imposed herein.

(c) Upon agreement of the Parties, Tenant may pay rent by electronic funds transfer and in such event, Landlord agrees to provide to Tenant bank routing information for such purpose upon request of Tenant.

(d) The annual rent shall increase annually each year of the term, including throughout each and every extension term, on each anniversary of the Commencement Date by an amount equal to two percent (2%) of the previous year's annual rent.

(e) Within ninety (90) days after the full execution of this Agreement, Tenant shall pay to Landlord the sum of Five Thousand Dollars (\$5,000.00) for Landlord's costs associated with the

legal review and document preparation of this Agreement, which payment shall be non-refundable.

#### **4. EXTENSIONS**

(a) This Agreement will automatically renew for five (5) additional five (5) year terms, upon the same terms and conditions (subject to the annual adjustment of rent), unless the Agreement has been terminated pursuant to Section 6 hereof, or the Tenant notifies the Landlord in writing of the Tenant's intention not to renew this Agreement at least ninety (90) days prior to the expiration of the existing term. Each five (5) year term shall be defined as the "Extension Term" and the Initial Term and any Extension Terms are collectively referred to as the "Term".

(b) The lease of the Premises shall terminate upon the expiration of the Term ("Expiration Date") and Tenant shall vacate the Premises and restore the Premises as nearly as possible to the condition as it existed before the Commencement Date, reasonable wear and tear excepted. If the Tenant fails to vacate the Premises as of the Expiration Date, Tenant will be deemed to be occupying the Premises on a month-to-month basis (the "Holdover Term"), subject to all the terms and conditions of this Agreement at then-current rent, except that the rental due shall be one hundred and fifty percent (150%) of the amount of rent that was applicable in the last year of the lease prior to expiration, subject to the annual escalator of five percent (5%). Notwithstanding the payment of rent during the Holdover Term, Landlord shall have the right to evict Tenant at any time during the holding over after the Expiration Date.

#### **5. APPROVALS**

(a) Tenant shall be solely responsible for securing and maintaining any and all government licenses, permits and approvals, (collectively, the "Government Approvals") required to construct and operate the Communication Facility, at Tenant's expense. Landlord makes no representation or warranty regarding the suitability of the Premises for Tenant's use or the feasibility of obtaining Government Approvals. Landlord authorizes Tenant to prepare, execute and file all required applications to obtain Governmental Approvals for Tenant's Permitted Use under this Agreement. Tenant shall have the right to initiate the ordering and/or scheduling of necessary utilities.

(b) Tenant has the right to obtain, at Tenant's sole cost and expense, a title report or commitment for a leasehold title policy from a title insurance company of its choice and to have the Property surveyed by a surveyor of Tenant's choice. In the event Tenant determines, in its sole discretion, due to the title report results or survey results, that the condition of the Premises is unsatisfactory, Tenant will have the right to terminate this Agreement prior to the Commencement Date upon notice to Landlord. If Tenant terminates this Agreement prior to the Commencement Date pursuant to this section, Tenant will be responsible for restoring the Premises as near as possible to its condition as it existed before the Effective Date.

(c) Tenant may also perform and obtain, at Tenant's sole cost and expense, soil borings, percolation tests, engineering procedures, environmental investigation or other tests or reports on, over, and under the Property, necessary to determine if the Tenant's use of the Premises

will be compatible with Tenant's engineering specifications, system, design, operations or Governmental Approvals.

(d) The parties acknowledge that Landlord, in executing this Agreement, is acting solely in its capacity as the owner of the Property and the Premises and not in any governmental or regulatory capacity. Tenant shall not consider this Agreement as a Governmental Approval for the construction or operation of Tenant's Communications Facility.

## 6. TERMINATION

This Agreement may be terminated, without penalty or further liability - except as provided herein- as follows:

(a) by the non-defaulting party on thirty (30) days prior written notice, if the defaulting party remains in default under Section 15 Default and Right to Cure of this Agreement after the applicable cure period provided that no such notice of termination shall be permitted if the defaulting party has commenced to cure such default within such cure period and prosecutes such cure to completion with reasonable diligence;

(b) by Tenant upon written notice to Landlord, if Tenant is unable to obtain, or maintain, any Governmental Approvals necessary for the construction or operation of the Communication Facility as now or hereafter intended by Tenant;

(c) by Tenant upon sixty (60) days prior written notice and restoration of the Premises to the condition which existed before the Effective Date and payment to Landlord of a termination fee equal to three (3) months of rent, at the then current rate, provided, however, that no such termination fee will be payable on account of the termination of this Agreement by Tenant under any one or more of Paragraphs 5(b) Approvals, 6(a) Termination, 6(b) Termination, 8 Interference, 11(d) Environmental, 18 Severability, 19 Condemnation or 20 Casualty of this Agreement.

## 7. INSURANCE

(a) During the Term, Tenant will carry, at its own cost and expense, the following insurance:

(i) Workers' compensation insurance as required by law;

(ii) commercial general liability (CGL) insurance with respect to its activities on the Property including liability arising from a negligent, or wrongful act of Tenant, such insurance to afford protection of Three Million Dollars (\$3,000,000) per occurrence and Six Million Dollars (\$6,000,000) general aggregate, based on Insurance Services Office (ISO) Form or a substitute form providing substantially equivalent coverage. Required limits may be satisfied with a combination of primary and excess/umbrella liability insurance. Tenant's CGL insurance shall contain a provision including Landlord as an additional insured as their interest may appear under this Agreement. Such additional insured coverage:

(1) shall be limited to bodily injury, property damage or personal and advertising injury caused, in whole or in part, by Tenant or its employees;



(2) shall not extend to claims for punitive or exemplary damages arising out of the acts or omissions of Landlord, its employees, agents or independent contractors or where such coverage is prohibited by law or to claims arising out of the gross negligence of Landlord, its employees, agents or independent contractors; and

(3) shall not exceed Tenant's indemnification obligation under this Agreement, if any.

(iii) Automobile Liability insurance (written on ISO form or its equivalent) with a combined single limit of liability of \$1 million each accident for bodily injury and property damage covering all "owned," "hired" and "non-owned" vehicles used in Tenant's business operations.

(iv) Commercial Property Insurance including coverage while under construction and installation. Such coverage shall:

(1) Provide coverage for Premises and Tenant's Communications Facility on the Premises. This coverage shall be at least as broad as that provided by the ISO Causes-of-Loss Special Form, including earthquake (if Tenant deems it reasonable), Ordinance or Law Coverage, flood, and Business Interruption equal to one (1) year's annual rent ;

(b) All insurance provided hereunder shall include a "separation of insureds" clause and shall apply separately to each insured and additional insured against whom a claim is made or suit is brought, except with respect to the limits of the insurer's liability. No policy shall contain any provision or exclusion (including a "cross-liability" or similar exclusion) that in effect would prevent, bar, or otherwise preclude any insured or additional insured under the policy from making a claim that would otherwise be covered by such policy on the grounds that the claim is brought by an insured or additional insured against an insured or additional insured under the policy.

(c) Notwithstanding the foregoing, Tenant may self-insure the coverages required in subsection (a). In the event Tenant elects to self-insure its obligation to include Landlord as an additional insured, the following provisions shall apply (in addition to those set forth in subsection (a)):

(i) Landlord shall promptly and no later than thirty (30) days after notice thereof provide Tenant with written notice of any claim, demand, lawsuit, or the like for which it seeks coverage pursuant to this Section and provide Tenant with copies of any demands, notices, summonses, or legal papers received in connection with such claim, demand, lawsuit, or the like;

(ii) Landlord shall not settle any such claim, demand, lawsuit, or the like without the prior written consent of Tenant; and

(iii) Landlord shall fully cooperate with Tenant in the defense of the claim, demand, lawsuit, or the like.

(d) Concurrently with Tenant's execution hereof, Tenant shall deliver to Landlord certificates of insurance and blanket additional insured endorsements providing the required additional insured status on insurance policies. The evidence provided must be adequate to allow Landlord to determine if all insurance requirements have been met. Landlord shall have no duty to perform under the Agreement until such evidence of insurance, in compliance with all

requirements of this section has been provided. Tenant shall promptly deliver to landlord evidence of insurance with respect to each renewal policy, as necessary to demonstrate the maintenance of the required insurance coverages for the duration of the Agreement. Such evidence shall be delivered to Landlord within seven (7) days of the expiration or renewal date of any policy.

## **8. INTERFERENCE**

(a) The following are preexisting radio frequencies licensed for use by Landlord on the Property or the Fire Station adjacent to the Property: 130- 180 VHF Mega Hurst and 799-817, 821-825, 851-860 Mega Hurst. Tenant shall be responsible for evaluating the potential for interference with these frequencies. The Communication Facility shall not disturb the communications configurations, equipment and frequencies which exist on the Commencement Date on the Property or properties adjacent to the Property which are owned or operated by or for the benefit of Landlord, ("Preexisting Communications") and the Communication Facility shall comply with all noninterference rules of the Federal Communications Commission ("FCC"). In the event any Tenant equipment causes such interference, and after Landlord has notified Tenant in writing of such interference, Tenant will take all commercially reasonable steps necessary to correct and eliminate the interference, including but not limited to, at Tenant's option, powering down such equipment and later powering up such equipment for intermittent testing. If such interference cannot be corrected within seven (7) days of Tenant's receipt of written notice of such interference, Landlord may require that Tenant cease (or cause the cessation of) operation of the interfering equipment until such interference can be so corrected at which time the operation of such equipment may resume. In no event will Landlord be entitled to terminate this Agreement or relocate the equipment as long as Tenant is making a good faith effort to remedy the interference issue.

(b) Landlord shall permit the installation of only such equipment that is of the type and frequency which will not cause harmful interference which is measurable in accordance with then existing industry standards to the communications operations of Tenant described in Section 2, above, with the exception of Preexisting Communications and any existing or future communication equipment required solely for the Landlord's business operations which shall not be deemed to cause interference. In the event any such harmful interference does not cease within twenty-four (24) hours after receipt of notice of interference from Tenant, the parties acknowledge that continuing interference will cause irreparable injury to Tenant, and therefore, Tenant shall have the right to bring action to enjoin such interference or to terminate this Agreement immediately upon notice to Landlord.

(c) Unless such activity is necessary to Landlord's use of the Property or the Fire Station for the purpose of providing public services, or conducting the business of the Landlord, Landlord will not use, nor will Landlord permit its employees, tenants, licensees, invitees or agents to use, any portion of the Property in any way which unreasonably interferes with the Communication Facility, the operations of Tenant or the rights of Tenant under this Agreement. Landlord will cause such interference to cease within twenty-four (24) hours after receipt of notice of interference from Tenant. In the event any such interference does not cease within the aforementioned cure period then the parties acknowledge that Tenant will suffer irreparable injury, and therefore, Tenant will have the right, in addition to any other rights that it may have at law or in

equity, for Landlord's breach of this Agreement, to elect to enjoin such interference or to terminate this Agreement upon notice to Landlord.

**9. INDEMNIFICATION**

(a) Tenant agrees to indemnify, defend and hold Landlord, its successors and assigns and its officials, officers, agents, employees, invitees, engineers, contractors and subcontractors, harmless from and against any and all injury, loss, damage or liability (and any claims in respect of the foregoing), costs or expenses (including reasonable attorneys' fees and court costs) directly caused by Tenant's or its officers', agents', employees', contractors', or subcontractors' installation, use, maintenance, repair or removal of the Communication Facility or resulting from or arising out of the negligence or willful misconduct or omission of Tenant, its officers, agents, employees, contractors, or subcontractors, except to the extent that such claim is proximately caused by the active negligence or willful misconduct of Landlord or its officers, agents, employees, engineers, contractors or subcontractors who are directly responsible to Landlord.

(b) Landlord agrees to indemnify, defend and hold Tenant, its successors and assigns and its officers, agents, employees, engineers, contractors and subcontractors, harmless from and against any and all injury, loss, damage or liability (or any claims in respect of the foregoing), costs or expenses (including reasonable attorneys' fees and court costs) directly caused by the active negligence or willful misconduct of Landlord or its employees or agents, or Landlord's breach of any provision of this Agreement, except to the extent attributable to the active negligence or intentional act or omission of Tenant, its employees, agents or independent contractors.

(c) Notwithstanding anything to the contrary in this Agreement, the Parties waive any claims they may have against the other with respect to consequential, incidental or special damages.

**10. REPRESENTATIONS AND WARRANTIES**

(a) Tenant represents that it is duly organized, validly existing and in good standing and has the right, power and authority to enter into this Agreement and bind itself hereto through the party set forth as signatory for the party below. Tenant represents and warrants that its execution and performance of this Agreement will not violate any laws, ordinances, or covenants.

(b) Landlord represents and warrants that: (i) Landlord solely owns the Property as a legal lot in fee simple, or controls the Property by lease or license; (ii) the Property is not encumbered by any liens, restrictions, mortgages, covenants, conditions, easements, leases, or any other agreements of record or not of record, which would adversely affect Tenant's Permitted Use and enjoyment of the Premises under this Agreement; (iii) as long as Tenant is not in default, and this Agreement has not been terminated, then Landlord grants to Tenant quiet and peaceful use, enjoyment and possession of the Premises; and (iv) if the Property is or becomes encumbered by a deed to secure a debt, mortgage or other security interest, Landlord shall provide promptly to Tenant a mutually agreeable Subordination, Non-Disturbance and Attornment Agreement for the benefit of Tenant confirming that Tenant's right to quiet possession of the Premises during this Agreement shall not be disturbed so long as Tenant has not defaulted under this Agreement and the Agreement has not been terminated.

(c) LANDLORD MAKES NO WARRANTY OR REPRESENTATION WHATSOEVER CONCERNING THE PROPERTY OR THE PREMISES, INCLUDING WITHOUT LIMITATION, THE CONDITION, FITNESS OR UTILITY FOR ANY PURPOSE THEREOF, OF ANY IMPROVEMENTS THERETO WITH APPLICABLE LAWS, ORDINANCES OR GOVERNMENTAL REGULATIONS. TENANT'S RIGHT TO USE PREMISES IS STRICTLY ON AN "AS IS" BASIS WITH ALL FAULTS. LANDLORD HEREBY DISCLAIMS ALL WARRANTIES WHATSOEVER, EXPRESS OR IMPLIED, THE CONDITION OF THE SOIL (OR WATER), GEOLOGY, AND ANY WARRANTY OF MERCHANTABILITY OR HABITABILITY OR FITNESS FOR ANY PARTICULAR PURPOSE.

**11. ENVIRONMENTAL.**

(a) Landlord and Tenant each agree that they will not use, generate, store or dispose of any Hazardous Material on, under, about or within Landlord's Property in violation of any law or regulation as may now or at any time hereafter be in effect. "Hazardous Material" shall mean any substance, chemical or waste identified as hazardous, toxic or dangerous in any applicable federal, state or local law or regulation (including petroleum and asbestos).

(b) Landlord and Tenant agree to hold harmless and indemnify the other from, and to assume all duties, responsibilities and liabilities at the sole cost and expense of the indemnifying party for, payment of penalties, sanctions, forfeitures, losses, costs or damages, and for responding to any action, notice, claim, order, summons, citation, directive, litigation, investigation or proceeding to the extent resulting from the indemnifying party's failure to comply with any environmental or industrial hygiene law, including without limitation any regulations, guidelines, standards or policies of any governmental authorities regulating or imposing standards of liability or standards of conduct with regard to any environmental or industrial hygiene conditions or matters as may now or hereafter be in effect. Tenant shall not be liable for or responsible for addressing environmental conditions that result from Hazardous Material that existed on the Property before the execution of this Agreement, or that otherwise do not result from Tenant's activities.

(c) The indemnifications of this Paragraph 11 Environmental specifically include reasonable costs, expenses and fees incurred in connection with any investigation of Property conditions or any clean-up, remediation, removal or restoration work required by any governmental authority.

(d) In the event Tenant becomes aware of any hazardous materials on the Property, or any environmental or industrial hygiene condition or matter relating to the Property that was not caused by Tenant and which, in Tenant's sole determination, renders the condition of the Premises or Property unsuitable for Tenant's use, or if Tenant believes that the leasing or continued leasing of the Premises would expose Tenant to undue risks of government action, intervention or third-party liability, Tenant will have the right, in addition to any other rights it may have at law or in equity, to terminate the Agreement upon notice to Landlord.

(e) Tenant shall, within forty-eight (48) hours of the discovery by Tenant of the presence of, or believed presence of, a Hazardous Substance as defined herein on, under, about or

within Premises, give written notice to Landlord. The failure to disclose in a timely manner the release of a Hazardous Substance, including but not limited to, an amount which is required to be reported to a state or local agency pursuant to law (e.g., California's Hazardous Materials Storage and Emergency Response Act, Health and Safety Code Section 25550 et seq.) shall be grounds for termination of this Lease by Landlord in addition to actual damages and other remedies provided by law. Tenant shall immediately clean up and completely remove all Hazardous Substances placed by Tenant on, under, about or within Premises, in a manner that is in all respects safe and in accordance with all applicable laws, rules and regulations.

(f) The provisions of this Paragraph 11 Environmental will survive the expiration or termination of this Agreement.

## **12. ACCESS TO PROPERTY AND PREMISES**

(a) All access to the Premises by Tenant shall be subject in each instance to the security requirements, rules and regulations in effect at the Property. At all times throughout the Term of this Agreement, and at no additional charge to Tenant, Tenant and its employees, agents, and subcontractors, will have twenty-four (24) hour per day, seven (7) day per week pedestrian and vehicular access over the Property to the Premises, for the installation, maintenance and operation of the Communication Facility and any utilities serving the Premises. After-hours access shall be for emergency purposes only. In the event any public utility is unable to use the access provided to Tenant then the Landlord agrees to grant additional access either to Tenant or to the public utility, for the benefit of Tenant, at no cost to Tenant.

(b) Landlord shall be responsible for maintaining and repairing the paved driveway and parking lot existing on the Property, except for damage caused by Tenant's use of such paved driveway and parking lot. If Tenant causes any such damage, it shall promptly repair the same using like materials, and if Tenant fails to make repairs within forty five (45) days of notice from Landlord, or such longer period as may reasonably be required, Landlord may make such repairs at Tenant's cost. Tenant shall reimburse Landlord the costs of such repairs upon receipt of an invoice for same.

(c) Tenant shall have the right to install utilities, at Tenant's expense, and to improve the present utilities on or near the Premises. Subject to Landlord's approval of the location and manner of installation. Tenant shall have the right to place utilities on (or bring utilities across) Landlord's Property in order to serve the Premises and the Communication Facility.

(d) Upon prior notice to Tenant and Tenant's opportunity to have its representative present, Landlord, its officers, employees and agents shall have the right to enter the Premises at any time for purposes of inspection. Tenant acknowledges that Landlord may enter without prior notice and/or without Tenant's opportunity to have its representative present in the event of an emergency or danger to public health and safety. Tenant shall provide Landlord a copy of any keys or access codes necessary to enter the Premises.

## **13. REMOVAL/RESTORATION/REMOVAL BOND**

(a) All portions of the Communication Facility brought onto the Property by Tenant will be and remain Tenant's personal property. Landlord covenants and agrees that no part of the Communication Facility constructed, erected or placed on the Premises by Tenant will become, or be considered as being affixed to or a part of, the Property, it being the specific intention of the Landlord that all improvements of every kind and nature constructed, erected or placed by Tenant on the Premises will be and remain the property of the Tenant during the Term. Tenant shall remove all of the Communication Facility at its sole expense within (90) days after the expiration, cancellation or early termination of the Term. Tenant shall repair any damage to the Premises caused by such removal and shall return the Premises to the condition which existed before the Commencement Date, reasonable wear and tear and casualty damage excepted.

(b) On or before the Commencement Date hereunder, Tenant shall to obtain a faithful performance bond, in the amount of at least Ten Thousand Dollars (\$10,000.00), from a bond company duly licensed to do business in the state in which the Property is located in favor of Landlord (the "Bond"). The Bond shall secure Tenant's removal of its equipment from the Premises following the expiration or earlier termination of the Lease, and shall be maintained in force by Tenant throughout the Term. Tenant agrees to deliver to Landlord a copy of the Bond prior to commencement of construction activities on the Premises. Prior to the commencement of any Extension Term, Landlord and Tenant shall review the amount of the Bond to assess whether the amount of the Bond is reasonably sufficient to cover removal and restoration costs. If it is reasonably determined to be insufficient, Tenant shall obtain and maintain in force a Bond for such additional amount that Landlord reasonably determines to be sufficient. Tenant acknowledges that Tenant is not entitled to relocation assistance, or any other benefits under the Uniform Relocation Assistance Act, or any other applicable provision of law upon termination of this Agreement.

#### **14. MAINTENANCE/UTILITIES**

(a) Tenant will keep and maintain the Communications Facility and Premises in good condition (including removal of any graffiti), reasonable wear and tear and damage from the elements excepted. Landlord will maintain and repair the Property and access thereto, in good and tenantable condition, subject to reasonable wear and tear and damage from the elements.

(b) Tenant will be responsible for securing separately metered services and paying on a monthly or quarterly basis all utilities charges for electricity, telephone service or any other utility used or consumed by Tenant on the Premises.

#### **15. DEFAULT AND RIGHT TO CURE**

(a) The following will be deemed a default by Tenant and a breach of this Agreement:  
(i) non-payment of rent if such rent and any applicable late charges remain unpaid for more than twenty (20) days after receipt of written notice from Landlord of such failure to pay; or (ii) Tenant's failure to perform any other term or condition under this Agreement within forty-five (45) days after receipt of written notice from Landlord specifying the failure. Delay in curing a default will be excused if due to causes beyond the reasonable control of Tenant. If Tenant remains in default beyond any applicable cure period, Landlord will have the right to exercise any and all rights and remedies available to it under this Agreement and under law and equity.

(b) The following will be deemed a default by Landlord and a breach of this Agreement: Landlord's failure to perform any term, condition or breach of any warranty or covenant under this Agreement within forty-five (45) days after receipt of written notice from Tenant specifying the failure. Delay in curing a default will be excused if due to causes beyond the reasonable control of Landlord. If Landlord remains in default beyond any applicable cure period, Tenant will have the right to exercise any and all rights available to it under this Agreement and under law and equity.

**16. ASSIGNMENT/SUBLEASE**

(a) Tenant may not assign, sublet or otherwise transfer all or any part of its interest in this Agreement or in the Premises without the prior written consent of Landlord; provided however, that Tenant may assign its interest to its parent company, any subsidiary or affiliate. Landlord may assign this Agreement upon written notice to Tenant.

(b) Tenant may sublet any portion of the Communications Facility or Premises to a third party or otherwise allow a third party to use the Communications Facility or Premises. Any sub-lessee must enter into a separate ground lease with the Landlord

**17. NOTICES**

All notices hereunder must be in writing and shall be deemed validly given if sent by certified mail, return receipt requested or by commercial courier, provided the courier's regular business is delivery service and provided further that it guarantees delivery to the addressee by the end of the next business day following the courier's receipt from the sender, addressed as follows (or any other address that the Party to be notified may have designated to the sender by like notice):

If to Landlord:           Town of Apple Valley  
                                  Attn: Assistant Town Manager  
                                  14955 Dale Evans Parkway  
                                  Apple Valley, CA 92307

With a copy to           Town of Apple Valley  
                                  Attn: Town Attorney  
                                  Best Best and Krieger, LLP  
                                  2855 East Guasti Road  
                                  Suite 400  
                                  Ontario, CA 91761

The copy sent to the Landlord's Attorney is an administrative step which alone does not constitute legal notice.

If to Tenant:            Los Angeles SMSA Limited Partnership,  
                                  d/b/a Verizon Wireless  
                                  180 Washington Valley Road  
                                  Bedminster, New Jersey 07921

Attention: Network Real Estate

Notice shall be effective upon actual receipt or refusal as shown on the receipt obtained pursuant to the foregoing. Either party hereto may change the place for the giving of notice to it by thirty (30) days prior written notice to the other as provided herein.

**18. SEVERABILITY**

If any term or condition of this Agreement is found unenforceable, the remaining terms and conditions will remain binding upon the parties as though said unenforceable provision were not contained herein. However, if the invalid, illegal or unenforceable provision materially affects this Agreement then the Agreement may be terminated by either party on thirty (30) days prior written notice to the other party hereto.

**19. CONDEMNATION**

In the event Landlord receives notification of any condemnation proceedings affecting the Property, Landlord will provide notice of the proceeding to Tenant within seven (7) days. If a condemning authority takes all of the Property, or a portion sufficient, in Tenant's sole determination, to render the Premises unsuitable for Tenant, this Agreement will terminate as of the date the title vests in the condemning authority. The parties will each be entitled to pursue their own separate awards in the condemnation proceeds, which for Tenant will include, where applicable, the value of its Communication Facility, moving expenses, prepaid rent, and business dislocation expenses, provided that any award to Tenant will not diminish Landlord's recovery.

**20. CASUALTY**

If any part of the Communication Facility or Property is damaged by fire or other casualty so as to render the Premises unsuitable, in Tenant's sole determination, then Tenant may terminate this Agreement by providing written notice to the Landlord, which termination will be effective as of the date of such damage or destruction. Upon such termination, Tenant will be entitled to collect all insurance proceeds payable to Tenant on account thereof and to be reimbursed for any prepaid rent on a pro-rata basis. If notice of termination is given, Tenant shall remove the Communication Facility and restore the Premises pursuant to Section 13. If Tenant elects not to give notice of termination and Tenant undertakes to rebuild the Communications Facility, Tenant shall continue to pay the applicable rent and Landlord agrees to use its reasonable efforts to permit Tenant to place temporary transmission and reception facilities on the Property at no additional rent until such time as the reconstruction of the Communication Facility is completed. The temporary transmission and reception facilities shall be removed and the Property restored within thirty (30) days of the completion of the rebuilding of the Communications Facility.

**21. TAXES**

Landlord hereby provides notice pursuant to California Revenue and Taxation Code Section 107.6, and Tenant acknowledges that this Agreement may create a possessory interest and Tenant may be subject to property taxes levied on such interest, as described in California Revenue and Taxation Code Section 107. Tenant shall pay, when due, all real and personal property taxes, fees and assessments, assessed against the Premises and the Communication Facility and Landlord

*Page 13 of 19*

*VERIZON - MENDEL PARK*

4837-4897-4174.1

Site Name: Chola / 69498.00068 / Site Lease Agreement



shall pay when due, all real property taxes and all other taxes, fees and assessments, if any attributable to the Property, exclusive of the Premises and the Communication Facility. Landlord shall provide Tenant with copies of all assessment notices on or including the Premises and Communication Facility immediately upon receipt, but in no event less than fifteen (15) business days after receipt by Landlord. Tenant shall have the right to contest, in good faith, the validity or the amount of any tax or assessment levied against the Premises and the Communication Facility by such appellate or other proceedings as may be appropriate in the jurisdiction, and may pay same under protest, or take such other steps as Tenant may deem appropriate. This right shall include the ability to institute any legal, regulatory or informal action in the name of Landlord, Tenant, or both, with respect to the valuation of the Premises and the Communication Facility. Landlord shall cooperate in the institution and prosecution of any such proceedings and will execute any documents required therefore, provided Landlord shall not be obligated to incur any cost or expense in connection therewith. All cost and expense of any such proceedings shall be borne by Tenant and any refunds or rebates secured as a result of Tenant's action shall belong to Tenant.

## **22. PREVAILING WAGES**

(a) Tenant acknowledges that Landlord has made no representation, express or implied, to Tenant or any person associated with Tenant regarding whether or not laborers employed relative to the construction of the improvements to be constructed pursuant to this Agreement must be paid the prevailing per diem wage rate for their labor classification, as determined by the State of California, pursuant to Labor Code Section 1720, et seq. ("Prevailing Wage Laws"). Tenant agrees with Landlord that Tenant shall assume any and all responsibility and be solely responsible for determining whether or not laborers employed relative to the construction undertaken pursuant to this Agreement must be paid the prevailing per diem wage rate pursuant to the Prevailing Wage Laws or other applicable law.

(b) Tenant, on behalf of itself, its successors, and assigns, waives and releases Landlord from any right of action that may be available to any of them pursuant to Labor Code Section 1781 or any similar law. Relative to the waiver and release set forth in this Section, Tenant acknowledges the protections of Civil Code Section 1542, which reads as follows:

A general release does not extend to claims which the creditor does not know or suspect to exist in his favor at the time of executing the release, which if known by him must have materially affected his settlement with the debtor.

(c) By executing this Agreement below, Tenant knowingly and voluntarily waives the provisions of Section 1542 or any similar law solely in connection with the waivers and releases contained in this Section.

## **23. SALE OF PROPERTY**

If during Term of this Agreement Landlord decides to sell the Property to a purchaser other than Tenant, Landlord shall promptly notify Tenant in writing, and such sale shall be subject to this Agreement and Tenant's rights hereunder. In the event the Property is transferred, the new landlord shall have a duty at the time of such transfer to provide Tenant with a completed IRS Form W-9, or

its equivalent, a completed IRS CA Form 590, or its equivalent, and other related paper work to effect a transfer in rent to the new landlord.

## 24. MISCELLANEOUS

(a) Amendment/Waiver. This Agreement cannot be amended, modified or revised unless done in writing and signed by an authorized agent of the Landlord and an authorized agent of the Tenant. No provision may be waived except in a writing signed by both parties.

(b) Memorandum/Short Form Lease. Either party will, at any time upon thirty (30) business day's prior written notice from the other, execute, acknowledge and deliver to the other a recordable Memorandum or Short Form of Lease. Either party may record this Memorandum or Short Form of Lease at any time, in its absolute discretion.

(c) Bind and Benefit. The terms and conditions contained in this Agreement will run with the Property and bind and inure to the benefit of the parties, their respective heirs, executors, administrators, successors and assigns.

(d) Entire Agreement. This Agreement and the exhibits attached hereto, all being a part hereof, constitute the entire agreement of the parties hereto and will supersede all prior offers, negotiations and agreements with respect to the subject matter of this Agreement.

(e) Governing Law and Venue. This Agreement will be governed by the laws of the State of California without regard to conflicts of laws. Venue for any disputes shall be in the state or federal courts located in San Bernardino County.

(f) Interpretation. Unless otherwise specified, the following rules of construction and interpretation apply: (i) captions are for convenience and reference only and in no way define or limit the construction of the terms and conditions hereof; (ii) use of the term "including" will be interpreted to mean "including but not limited to"; (iii) whenever a party's consent is required under this Agreement, except as otherwise stated in the Agreement or as same may be duplicative, such consent will not be unreasonably withheld, conditioned or delayed; (iv) exhibits are an integral part of the Agreement and are incorporated by reference into this Agreement; and (v) reference to a default will take into consideration any applicable notice, grace and cure periods.

(g) Estoppel. Either party will, at any time upon thirty (30) business days prior written notice from the other, execute, acknowledge and deliver to the other a statement in writing (i) certifying that this Agreement is unmodified and in full force and effect (or, if modified, stating the nature of such modification and certifying this Agreement, as so modified, is in full force and effect) and the date to which the rent and other charges are paid in advance, if any. Any such statement may be conclusively relied upon by any prospective purchaser or encumbrancer of the Premises.

(h) No Electronic Signature/No Option. The submission of this Agreement to any party for examination or consideration does not constitute an offer, reservation of or option for the Premises based on the terms set forth herein. This Agreement will become effective as a binding Agreement only upon the handwritten legal execution, acknowledgment and delivery hereof by Landlord and Tenant.

(i) Attorney's Fees. The prevailing party in any legal claim arising hereunder shall be entitled to recover from the other party its reasonable attorneys' fees and court costs, including appeals, if any.

(j) Survival. Terms and conditions of this Agreement, which by their sense and context survive the termination, cancellation, or expiration of this Agreement, will so survive.

[SIGNATURES APPEAR ON THE NEXT PAGE]

IN WITNESS WHEREOF, the Parties hereto have set their hands and affixed their respective seals the day and year first above written.

**LANDLORD:**  
**Town of Apple Valley, CA**

By: \_\_\_\_\_  
Its: \_\_\_\_\_

**TENANT:**  
**Los Angeles SMSA Limited Partnership,**  
**d/b/a Verizon Wireless**

By: AirTouch Cellular  
Its: General Partner

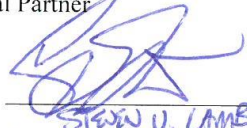
By:   
Name: STEVEN U. LAMB  
Its: 5/14/18

**EXHIBIT "A"**

**LEGAL DESCRIPTION OF THE PROPERTY AND PREMISES**

All that certain real property situated in the County of San Bernardino, State of California, described as follows:

THE SOUTH ½ OF THE SOUTHEAST ¼ OF THE SOUTHWEST ¼ OF THE SOUTHWEST ¼ OF SECTION 10, TOWNSHIP 4 NORTH, RANGE 3 WEST, SAN BERNARDINO BASE AND MERIDIAN, IN THE CITY OF APPLE VALLEY, COUNTY OF SAN BERNARDINO, STATE OF CALIFORNIA, EXCEPTING THE EASTERLY 99 FEET.

APN: 3080-104-06

**EXHIBIT "B"**  
**SITE PLAN OF THE PREMISES**  
**Attached**

4837-4897-4174.1  
Site Name: Chola / 69498.00068 / Site Lease Agreement

**NOTES**

1. THE UTILITY ROUTES SHOWN ARE CONCEPTUAL AND ARE SUBJECT TO CHANGE DUE TO FIELD CONDITIONS AND/OR DESIGN CHANGES REQUESTED BY THE UTILITY SERVICE PROVIDER OR CONSTRUCTION TEAM.
2. KEEP CONDUIT ROUTING OUTSIDE OF EASEMENT BOUNDARY.

PROPOSED GROUND LESSEE LEASE AREA:	±400 S.F.
PROPOSED AERIAL LESSEE LEASE AREA:	±150 S.F.
TOTAL PROPOSED LESSEE LEASE AREA:	±550 S.F.

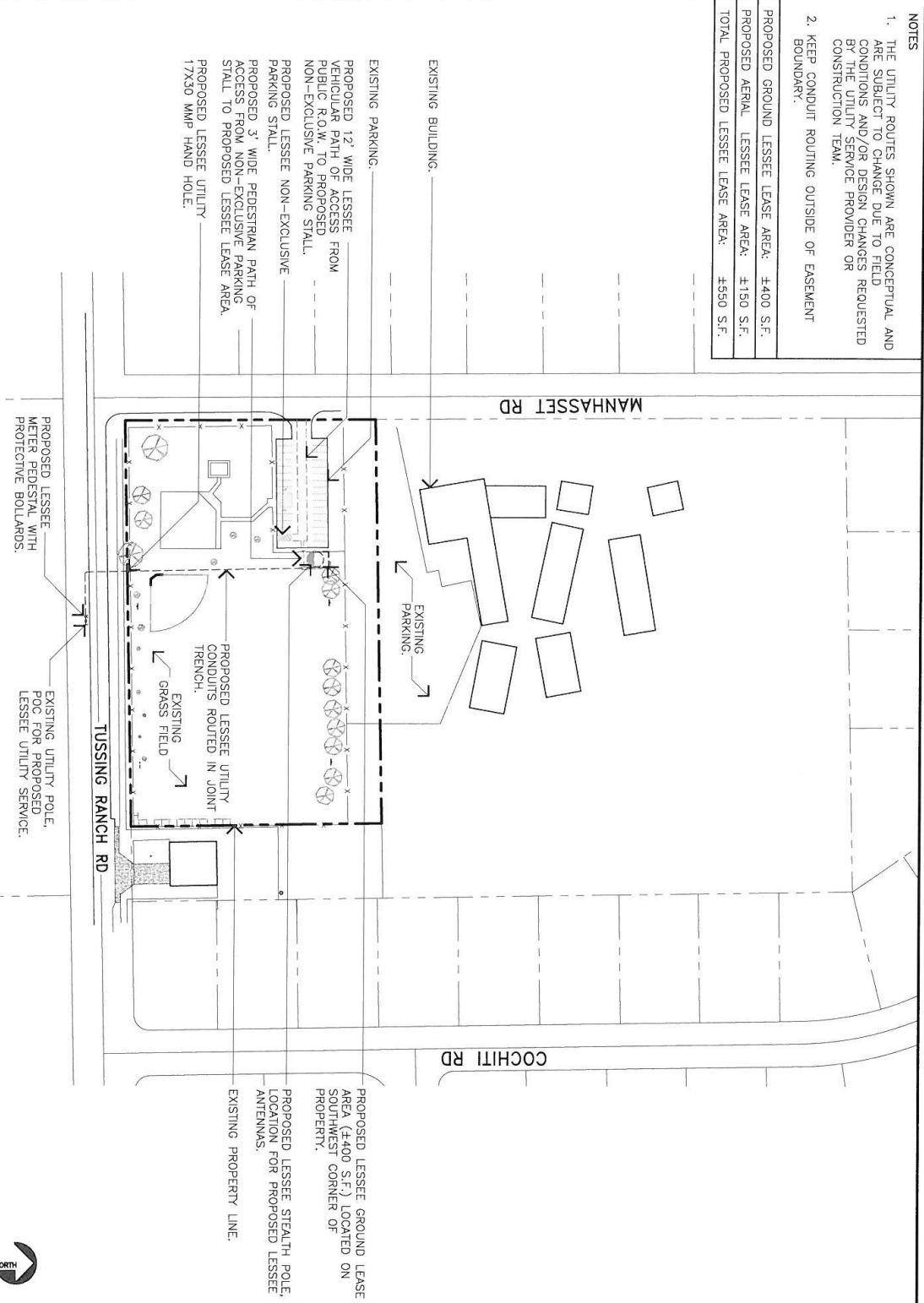

LEASE EXHIBIT – CHOLA – 21860 TUUSSING RANCH RD APPLE VALLEY, CA 92308

SCALE: NONE 1

JRA JOB NUMBER: 161352

CONTEXTUAL SITE PLAN

LEGEND

- 1. PROPOSED NEW PROJECT AREA SET 4'-1'
- 2. EXISTING LOT LINE TYPICAL
- 3. EXISTING SCHOOL BUILDING
- 4. EXISTING SCHOOL BUILDING TAIL
- 5. EXISTING PARKING AREA
- 6. EXISTING PARKING LOT TAIL
- 7. EXISTING DRAIN FIELD
- 8. EXISTING TWP MAIL
- 9. EXISTING 4'-1" HIGH DRAIN LOT FENCE
- 10. EXISTING 4'-1" HIGH DRAIN LOT FENCE
- 11. EXISTING 4'-1" HIGH DRAIN LOT FENCE
- 12. EXISTING 4'-1" HIGH DRAIN LOT FENCE
- 13. EXISTING 4'-1" HIGH DRAIN LOT FENCE
- 14. EXISTING 4'-1" HIGH DRAIN LOT FENCE
- 15. EXISTING 4'-1" HIGH DRAIN LOT FENCE
- 16. EXISTING 4'-1" HIGH DRAIN LOT FENCE
- 17. EXISTING 4'-1" HIGH DRAIN LOT FENCE
- 18. EXISTING 4'-1" HIGH DRAIN LOT FENCE
- 19. EXISTING 4'-1" HIGH DRAIN LOT FENCE
- 20. EXISTING 4'-1" HIGH DRAIN LOT FENCE
- 21. EXISTING 4'-1" HIGH DRAIN LOT FENCE
- 22. EXISTING 4'-1" HIGH DRAIN LOT FENCE
- 23. EXISTING 4'-1" HIGH DRAIN LOT FENCE
- 24. EXISTING 4'-1" HIGH DRAIN LOT FENCE
- 25. EXISTING 4'-1" HIGH DRAIN LOT FENCE
- 26. EXISTING 4'-1" HIGH DRAIN LOT FENCE
- 27. EXISTING 4'-1" HIGH DRAIN LOT FENCE
- 28. EXISTING 4'-1" HIGH DRAIN LOT FENCE
- 29. EXISTING 4'-1" HIGH DRAIN LOT FENCE
- 30. EXISTING 4'-1" HIGH DRAIN LOT FENCE
- 31. EXISTING 4'-1" HIGH DRAIN LOT FENCE
- 32. EXISTING 4'-1" HIGH DRAIN LOT FENCE
- 33. EXISTING 4'-1" HIGH DRAIN LOT FENCE
- 34. EXISTING 4'-1" HIGH DRAIN LOT FENCE
- 35. EXISTING 4'-1" HIGH DRAIN LOT FENCE
- 36. EXISTING 4'-1" HIGH DRAIN LOT FENCE
- 37. EXISTING 4'-1" HIGH DRAIN LOT FENCE
- 38. EXISTING 4'-1" HIGH DRAIN LOT FENCE
- 39. EXISTING 4'-1" HIGH DRAIN LOT FENCE
- 40. EXISTING 4'-1" HIGH DRAIN LOT FENCE
- 41. EXISTING 4'-1" HIGH DRAIN LOT FENCE
- 42. EXISTING 4'-1" HIGH DRAIN LOT FENCE
- 43. EXISTING 4'-1" HIGH DRAIN LOT FENCE
- 44. EXISTING 4'-1" HIGH DRAIN LOT FENCE
- 45. EXISTING 4'-1" HIGH DRAIN LOT FENCE
- 46. EXISTING 4'-1" HIGH DRAIN LOT FENCE
- 47. EXISTING 4'-1" HIGH DRAIN LOT FENCE
- 48. EXISTING 4'-1" HIGH DRAIN LOT FENCE
- 49. EXISTING 4'-1" HIGH DRAIN LOT FENCE
- 50. EXISTING 4'-1" HIGH DRAIN LOT FENCE
- 51. EXISTING 4'-1" HIGH DRAIN LOT FENCE
- 52. EXISTING 4'-1" HIGH DRAIN LOT FENCE
- 53. EXISTING 4'-1" HIGH DRAIN LOT FENCE
- 54. EXISTING 4'-1" HIGH DRAIN LOT FENCE
- 55. EXISTING 4'-1" HIGH DRAIN LOT FENCE
- 56. EXISTING 4'-1" HIGH DRAIN LOT FENCE
- 57. EXISTING 4'-1" HIGH DRAIN LOT FENCE
- 58. EXISTING 4'-1" HIGH DRAIN LOT FENCE
- 59. EXISTING 4'-1" HIGH DRAIN LOT FENCE
- 60. EXISTING 4'-1" HIGH DRAIN LOT FENCE
- 61. EXISTING 4'-1" HIGH DRAIN LOT FENCE
- 62. EXISTING 4'-1" HIGH DRAIN LOT FENCE
- 63. EXISTING 4'-1" HIGH DRAIN LOT FENCE
- 64. EXISTING 4'-1" HIGH DRAIN LOT FENCE
- 65. EXISTING 4'-1" HIGH DRAIN LOT FENCE
- 66. EXISTING 4'-1" HIGH DRAIN LOT FENCE
- 67. EXISTING 4'-1" HIGH DRAIN LOT FENCE
- 68. EXISTING 4'-1" HIGH DRAIN LOT FENCE
- 69. EXISTING 4'-1" HIGH DRAIN LOT FENCE
- 70. EXISTING 4'-1" HIGH DRAIN LOT FENCE
- 71. EXISTING 4'-1" HIGH DRAIN LOT FENCE
- 72. EXISTING 4'-1" HIGH DRAIN LOT FENCE
- 73. EXISTING 4'-1" HIGH DRAIN LOT FENCE
- 74. EXISTING 4'-1" HIGH DRAIN LOT FENCE
- 75. EXISTING 4'-1" HIGH DRAIN LOT FENCE
- 76. EXISTING 4'-1" HIGH DRAIN LOT FENCE
- 77. EXISTING 4'-1" HIGH DRAIN LOT FENCE
- 78. EXISTING 4'-1" HIGH DRAIN LOT FENCE
- 79. EXISTING 4'-1" HIGH DRAIN LOT FENCE
- 80. EXISTING 4'-1" HIGH DRAIN LOT FENCE
- 81. EXISTING 4'-1" HIGH DRAIN LOT FENCE
- 82. EXISTING 4'-1" HIGH DRAIN LOT FENCE
- 83. EXISTING 4'-1" HIGH DRAIN LOT FENCE
- 84. EXISTING 4'-1" HIGH DRAIN LOT FENCE
- 85. EXISTING 4'-1" HIGH DRAIN LOT FENCE
- 86. EXISTING 4'-1" HIGH DRAIN LOT FENCE
- 87. EXISTING 4'-1" HIGH DRAIN LOT FENCE
- 88. EXISTING 4'-1" HIGH DRAIN LOT FENCE
- 89. EXISTING 4'-1" HIGH DRAIN LOT FENCE
- 90. EXISTING 4'-1" HIGH DRAIN LOT FENCE
- 91. EXISTING 4'-1" HIGH DRAIN LOT FENCE
- 92. EXISTING 4'-1" HIGH DRAIN LOT FENCE
- 93. EXISTING 4'-1" HIGH DRAIN LOT FENCE
- 94. EXISTING 4'-1" HIGH DRAIN LOT FENCE
- 95. EXISTING 4'-1" HIGH DRAIN LOT FENCE
- 96. EXISTING 4'-1" HIGH DRAIN LOT FENCE
- 97. EXISTING 4'-1" HIGH DRAIN LOT FENCE
- 98. EXISTING 4'-1" HIGH DRAIN LOT FENCE
- 99. EXISTING 4'-1" HIGH DRAIN LOT FENCE
- 100. EXISTING 4'-1" HIGH DRAIN LOT FENCE

**SETBACK REQUIREMENTS:**  
 ALL EXISTING AND PROPOSED BUILDINGS SHALL BE SETBACK FROM THE FRONT LOT LINE BY A MINIMUM OF 10 FEET.  
 ALL EXISTING AND PROPOSED BUILDINGS SHALL BE SETBACK FROM THE SIDE LOT LINE BY A MINIMUM OF 5 FEET.  
 ALL EXISTING AND PROPOSED BUILDINGS SHALL BE SETBACK FROM THE REAR LOT LINE BY A MINIMUM OF 5 FEET.  
 ALL EXISTING AND PROPOSED BUILDINGS SHALL BE SETBACK FROM THE CORNER LOT LINE BY A MINIMUM OF 5 FEET.  
 ALL EXISTING AND PROPOSED BUILDINGS SHALL BE SETBACK FROM THE ADJACENT LOT LINE BY A MINIMUM OF 5 FEET.  
 ALL EXISTING AND PROPOSED BUILDINGS SHALL BE SETBACK FROM THE STREET BY A MINIMUM OF 10 FEET.  
 ALL EXISTING AND PROPOSED BUILDINGS SHALL BE SETBACK FROM THE DRIVE BY A MINIMUM OF 5 FEET.  
 ALL EXISTING AND PROPOSED BUILDINGS SHALL BE SETBACK FROM THE SIDEWALK BY A MINIMUM OF 5 FEET.  
 ALL EXISTING AND PROPOSED BUILDINGS SHALL BE SETBACK FROM THE CURB BY A MINIMUM OF 5 FEET.  
 ALL EXISTING AND PROPOSED BUILDINGS SHALL BE SETBACK FROM THE PARKING AREA BY A MINIMUM OF 5 FEET.  
 ALL EXISTING AND PROPOSED BUILDINGS SHALL BE SETBACK FROM THE DRAIN FIELD BY A MINIMUM OF 5 FEET.  
 ALL EXISTING AND PROPOSED BUILDINGS SHALL BE SETBACK FROM THE TWP MAIL BY A MINIMUM OF 5 FEET.  
 ALL EXISTING AND PROPOSED BUILDINGS SHALL BE SETBACK FROM THE DRAIN LOT FENCE BY A MINIMUM OF 5 FEET.

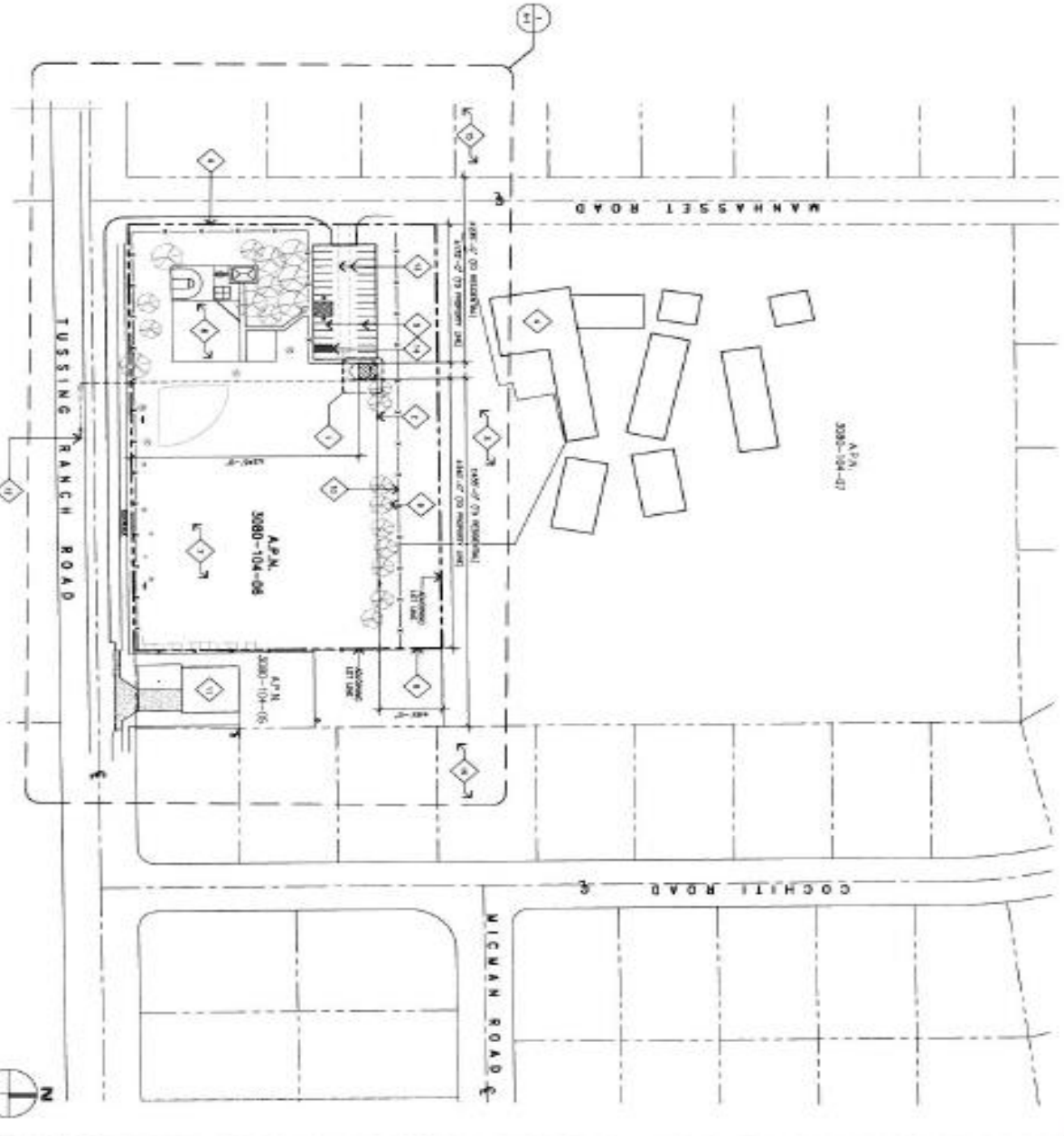

SCALE: 1"=40'  
 0 20 40  
 N

<p><b>A-0</b></p> <p>CHOLA                  21860 TUSSING RANCH RD                  APPLE VALLEY, CALIFORNIA                  92308</p>		<p><b>vertzon</b></p> <p>15025 SAND CANYON AVENUE, 01                  IRVINE, CA 92618</p>	<p><b>PROFESSIONAL INFORMATION:</b>                  I, the undersigned, being a duly licensed and qualified professional person in the State of California, do hereby certify that I am the author of the foregoing plans, specifications, and reports, and that I am a duly licensed and qualified professional person in the State of California.</p>	<p><b>Jalilay Rahimi</b>                  ARCHITECT                  11111 JEFFERSON DRIVE, SUITE 120                  IRVINE, CALIFORNIA 92618                  TEL: 949.440.1111                  FAX: 949.440.1112</p>	<p><b>ISSUE STATUS</b></p> <table border="1"> <tr> <th>NO.</th> <th>DATE</th> <th>DESCRIPTION</th> </tr> <tr> <td>1</td> <td>07/10/2018</td> <td>ISSUED FOR PUBLIC COMMENT</td> </tr> <tr> <td>2</td> <td>07/10/2018</td> <td>ISSUED FOR PUBLIC COMMENT</td> </tr> <tr> <td>3</td> <td>07/10/2018</td> <td>ISSUED FOR PUBLIC COMMENT</td> </tr> <tr> <td>4</td> <td>07/10/2018</td> <td>ISSUED FOR PUBLIC COMMENT</td> </tr> <tr> <td>5</td> <td>07/10/2018</td> <td>ISSUED FOR PUBLIC COMMENT</td> </tr> <tr> <td>6</td> <td>07/10/2018</td> <td>ISSUED FOR PUBLIC COMMENT</td> </tr> <tr> <td>7</td> <td>07/10/2018</td> <td>ISSUED FOR PUBLIC COMMENT</td> </tr> <tr> <td>8</td> <td>07/10/2018</td> <td>ISSUED FOR PUBLIC COMMENT</td> </tr> <tr> <td>9</td> <td>07/10/2018</td> <td>ISSUED FOR PUBLIC COMMENT</td> </tr> <tr> <td>10</td> <td>07/10/2018</td> <td>ISSUED FOR PUBLIC COMMENT</td> </tr> <tr> <td>11</td> <td>07/10/2018</td> <td>ISSUED FOR PUBLIC COMMENT</td> </tr> <tr> <td>12</td> <td>07/10/2018</td> <td>ISSUED FOR PUBLIC COMMENT</td> </tr> <tr> <td>13</td> <td>07/10/2018</td> <td>ISSUED FOR PUBLIC COMMENT</td> </tr> <tr> <td>14</td> <td>07/10/2018</td> <td>ISSUED FOR PUBLIC COMMENT</td> </tr> <tr> <td>15</td> <td>07/10/2018</td> <td>ISSUED FOR PUBLIC COMMENT</td> </tr> <tr> <td>16</td> <td>07/10/2018</td> <td>ISSUED FOR PUBLIC COMMENT</td> </tr> <tr> <td>17</td> <td>07/10/2018</td> <td>ISSUED FOR PUBLIC COMMENT</td> </tr> <tr> <td>18</td> <td>07/10/2018</td> <td>ISSUED FOR PUBLIC COMMENT</td> </tr> <tr> <td>19</td> <td>07/10/2018</td> <td>ISSUED FOR PUBLIC COMMENT</td> </tr> <tr> <td>20</td> <td>07/10/2018</td> <td>ISSUED FOR PUBLIC COMMENT</td> </tr> <tr> <td>21</td> <td>07/10/2018</td> <td>ISSUED FOR PUBLIC COMMENT</td> </tr> <tr> <td>22</td> <td>07/10/2018</td> <td>ISSUED FOR PUBLIC COMMENT</td> </tr> <tr> <td>23</td> <td>07/10/2018</td> <td>ISSUED FOR PUBLIC COMMENT</td> </tr> <tr> <td>24</td> <td>07/10/2018</td> <td>ISSUED FOR PUBLIC COMMENT</td> </tr> <tr> <td>25</td> <td>07/10/2018</td> <td>ISSUED FOR PUBLIC COMMENT</td> </tr> <tr> <td>26</td> <td>07/10/2018</td> <td>ISSUED FOR PUBLIC COMMENT</td> </tr> <tr> <td>27</td> <td>07/10/2018</td> <td>ISSUED FOR PUBLIC COMMENT</td> </tr> <tr> <td>28</td> <td>07/10/2018</td> <td>ISSUED FOR PUBLIC COMMENT</td> </tr> <tr> <td>29</td> <td>07/10/2018</td> <td>ISSUED FOR PUBLIC COMMENT</td> </tr> <tr> <td>30</td> <td>07/10/2018</td> <td>ISSUED FOR PUBLIC COMMENT</td> </tr> <tr> <td>31</td> <td>07/10/2018</td> <td>ISSUED FOR PUBLIC COMMENT</td> </tr> <tr> <td>32</td> <td>07/10/2018</td> <td>ISSUED FOR PUBLIC COMMENT</td> </tr> <tr> <td>33</td> <td>07/10/2018</td> <td>ISSUED FOR PUBLIC COMMENT</td> </tr> <tr> <td>34</td> <td>07/10/2018</td> <td>ISSUED FOR PUBLIC COMMENT</td> </tr> <tr> <td>35</td> <td>07/10/2018</td> <td>ISSUED FOR PUBLIC COMMENT</td> </tr> <tr> <td>36</td> <td>07/10/2018</td> <td>ISSUED FOR PUBLIC COMMENT</td> </tr> <tr> <td>37</td> <td>07/10/2018</td> <td>ISSUED FOR PUBLIC COMMENT</td> </tr> <tr> <td>38</td> <td>07/10/2018</td> <td>ISSUED FOR PUBLIC COMMENT</td> </tr> <tr> <td>39</td> <td>07/10/2018</td> <td>ISSUED FOR PUBLIC COMMENT</td> </tr> <tr> <td>40</td> <td>07/10/2018</td> <td>ISSUED FOR PUBLIC COMMENT</td> </tr> <tr> <td>41</td> <td>07/10/2018</td> <td>ISSUED FOR PUBLIC COMMENT</td> </tr> <tr> <td>42</td> <td>07/10/2018</td> <td>ISSUED FOR PUBLIC COMMENT</td> </tr> <tr> <td>43</td> <td>07/10/2018</td> <td>ISSUED FOR PUBLIC COMMENT</td> </tr> <tr> <td>44</td> <td>07/10/2018</td> <td>ISSUED FOR PUBLIC COMMENT</td> </tr> <tr> <td>45</td> <td>07/10/2018</td> <td>ISSUED FOR PUBLIC COMMENT</td> </tr> <tr> <td>46</td> <td>07/10/2018</td> <td>ISSUED FOR PUBLIC COMMENT</td> </tr> <tr> <td>47</td> <td>07/10/2018</td> <td>ISSUED FOR PUBLIC COMMENT</td> </tr> <tr> <td>48</td> <td>07/10/2018</td> <td>ISSUED FOR PUBLIC COMMENT</td> </tr> <tr> <td>49</td> <td>07/10/2018</td> <td>ISSUED FOR PUBLIC COMMENT</td> </tr> <tr> <td>50</td> <td>07/10/2018</td> <td>ISSUED FOR PUBLIC COMMENT</td> </tr> <tr> <td>51</td> <td>07/10/2018</td> <td>ISSUED FOR PUBLIC COMMENT</td> </tr> <tr> <td>52</td> <td>07/10/2018</td> <td>ISSUED FOR PUBLIC COMMENT</td> </tr> <tr> <td>53</td> <td>07/10/2018</td> <td>ISSUED FOR PUBLIC COMMENT</td> </tr> <tr> <td>54</td> <td>07/10/2018</td> <td>ISSUED FOR PUBLIC COMMENT</td> </tr> <tr> <td>55</td> <td>07/10/2018</td> <td>ISSUED FOR PUBLIC COMMENT</td> </tr> <tr> <td>56</td> <td>07/10/2018</td> <td>ISSUED FOR PUBLIC COMMENT</td> </tr> <tr> <td>57</td> <td>07/10/2018</td> <td>ISSUED FOR PUBLIC COMMENT</td> </tr> <tr> <td>58</td> <td>07/10/2018</td> <td>ISSUED FOR PUBLIC COMMENT</td> </tr> <tr> <td>59</td> <td>07/10/2018</td> <td>ISSUED FOR PUBLIC COMMENT</td> </tr> <tr> <td>60</td> <td>07/10/2018</td> <td>ISSUED FOR PUBLIC COMMENT</td> </tr> <tr> <td>61</td> <td>07/10/2018</td> <td>ISSUED FOR PUBLIC COMMENT</td> </tr> <tr> <td>62</td> <td>07/10/2018</td> <td>ISSUED FOR PUBLIC COMMENT</td> </tr> <tr> <td>63</td> <td>07/10/2018</td> <td>ISSUED FOR PUBLIC COMMENT</td> </tr> <tr> <td>64</td> <td>07/10/2018</td> <td>ISSUED FOR PUBLIC COMMENT</td> </tr> <tr> <td>65</td> <td>07/10/2018</td> <td>ISSUED FOR PUBLIC COMMENT</td> </tr> <tr> <td>66</td> <td>07/10/2018</td> <td>ISSUED FOR PUBLIC COMMENT</td> </tr> <tr> <td>67</td> <td>07/10/2018</td> <td>ISSUED FOR PUBLIC COMMENT</td> </tr> <tr> <td>68</td> <td>07/10/2018</td> <td>ISSUED FOR PUBLIC COMMENT</td> </tr> <tr> <td>69</td> <td>07/10/2018</td> <td>ISSUED FOR PUBLIC COMMENT</td> </tr> <tr> <td>70</td> <td>07/10/2018</td> <td>ISSUED FOR PUBLIC COMMENT</td> </tr> <tr> <td>71</td> <td>07/10/2018</td> <td>ISSUED FOR PUBLIC COMMENT</td> </tr> <tr> <td>72</td> <td>07/10/2018</td> <td>ISSUED FOR PUBLIC COMMENT</td> </tr> <tr> <td>73</td> <td>07/10/2018</td> <td>ISSUED FOR PUBLIC COMMENT</td> </tr> <tr> <td>74</td> <td>07/10/2018</td> <td>ISSUED FOR PUBLIC COMMENT</td> </tr> <tr> <td>75</td> <td>07/10/2018</td> <td>ISSUED FOR PUBLIC COMMENT</td> </tr> <tr> <td>76</td> <td>07/10/2018</td> <td>ISSUED FOR PUBLIC COMMENT</td> </tr> <tr> <td>77</td> <td>07/10/2018</td> <td>ISSUED FOR PUBLIC COMMENT</td> </tr> <tr> <td>78</td> <td>07/10/2018</td> <td>ISSUED FOR PUBLIC COMMENT</td> </tr> <tr> <td>79</td> <td>07/10/2018</td> <td>ISSUED FOR PUBLIC COMMENT</td> </tr> <tr> <td>80</td> <td>07/10/2018</td> <td>ISSUED FOR PUBLIC COMMENT</td> </tr> <tr> <td>81</td> <td>07/10/2018</td> <td>ISSUED FOR PUBLIC COMMENT</td> </tr> <tr> <td>82</td> <td>07/10/2018</td> <td>ISSUED FOR PUBLIC COMMENT</td> </tr> <tr> <td>83</td> <td>07/10/2018</td> <td>ISSUED FOR PUBLIC COMMENT</td> </tr> <tr> <td>84</td> <td>07/10/2018</td> <td>ISSUED FOR PUBLIC COMMENT</td> </tr> <tr> <td>85</td> <td>07/10/2018</td> <td>ISSUED FOR PUBLIC COMMENT</td> </tr> <tr> <td>86</td> <td>07/10/2018</td> <td>ISSUED FOR PUBLIC COMMENT</td> </tr> <tr> <td>87</td> <td>07/10/2018</td> <td>ISSUED FOR PUBLIC COMMENT</td> </tr> <tr> <td>88</td> <td>07/10/2018</td> <td>ISSUED FOR PUBLIC COMMENT</td> </tr> <tr> <td>89</td> <td>07/10/2018</td> <td>ISSUED FOR PUBLIC COMMENT</td> </tr> <tr> <td>90</td> <td>07/10/2018</td> <td>ISSUED FOR PUBLIC COMMENT</td> </tr> <tr> <td>91</td> <td>07/10/2018</td> <td>ISSUED FOR PUBLIC COMMENT</td> </tr> <tr> <td>92</td> <td>07/10/2018</td> <td>ISSUED FOR PUBLIC COMMENT</td> </tr> <tr> <td>93</td> <td>07/10/2018</td> <td>ISSUED FOR PUBLIC COMMENT</td> </tr> <tr> <td>94</td> <td>07/10/2018</td> <td>ISSUED FOR PUBLIC COMMENT</td> </tr> <tr> <td>95</td> <td>07/10/2018</td> <td>ISSUED FOR PUBLIC COMMENT</td> </tr> <tr> <td>96</td> <td>07/10/2018</td> <td>ISSUED FOR PUBLIC COMMENT</td> </tr> <tr> <td>97</td> <td>07/10/2018</td> <td>ISSUED FOR PUBLIC COMMENT</td> </tr> <tr> <td>98</td> <td>07/10/2018</td> <td>ISSUED FOR PUBLIC COMMENT</td> </tr> <tr> <td>99</td> <td>07/10/2018</td> <td>ISSUED FOR PUBLIC COMMENT</td> </tr> <tr> <td>100</td> <td>07/10/2018</td> <td>ISSUED FOR PUBLIC COMMENT</td> </tr> </table>	NO.	DATE	DESCRIPTION	1	07/10/2018	ISSUED FOR PUBLIC COMMENT	2	07/10/2018	ISSUED FOR PUBLIC COMMENT	3	07/10/2018	ISSUED FOR PUBLIC COMMENT	4	07/10/2018	ISSUED FOR PUBLIC COMMENT	5	07/10/2018	ISSUED FOR PUBLIC COMMENT	6	07/10/2018	ISSUED FOR PUBLIC COMMENT	7	07/10/2018	ISSUED FOR PUBLIC COMMENT	8	07/10/2018	ISSUED FOR PUBLIC COMMENT	9	07/10/2018	ISSUED FOR PUBLIC COMMENT	10	07/10/2018	ISSUED FOR PUBLIC COMMENT	11	07/10/2018	ISSUED FOR PUBLIC COMMENT	12	07/10/2018	ISSUED FOR PUBLIC COMMENT	13	07/10/2018	ISSUED FOR PUBLIC COMMENT	14	07/10/2018	ISSUED FOR PUBLIC COMMENT	15	07/10/2018	ISSUED FOR PUBLIC COMMENT	16	07/10/2018	ISSUED FOR PUBLIC COMMENT	17	07/10/2018	ISSUED FOR PUBLIC COMMENT	18	07/10/2018	ISSUED FOR PUBLIC COMMENT	19	07/10/2018	ISSUED FOR PUBLIC COMMENT	20	07/10/2018	ISSUED FOR PUBLIC COMMENT	21	07/10/2018	ISSUED FOR PUBLIC COMMENT	22	07/10/2018	ISSUED FOR PUBLIC COMMENT	23	07/10/2018	ISSUED FOR PUBLIC COMMENT	24	07/10/2018	ISSUED FOR PUBLIC COMMENT	25	07/10/2018	ISSUED FOR PUBLIC COMMENT	26	07/10/2018	ISSUED FOR PUBLIC COMMENT	27	07/10/2018	ISSUED FOR PUBLIC COMMENT	28	07/10/2018	ISSUED FOR PUBLIC COMMENT	29	07/10/2018	ISSUED FOR PUBLIC COMMENT	30	07/10/2018	ISSUED FOR PUBLIC COMMENT	31	07/10/2018	ISSUED FOR PUBLIC COMMENT	32	07/10/2018	ISSUED FOR PUBLIC COMMENT	33	07/10/2018	ISSUED FOR PUBLIC COMMENT	34	07/10/2018	ISSUED FOR PUBLIC COMMENT	35	07/10/2018	ISSUED FOR PUBLIC COMMENT	36	07/10/2018	ISSUED FOR PUBLIC COMMENT	37	07/10/2018	ISSUED FOR PUBLIC COMMENT	38	07/10/2018	ISSUED FOR PUBLIC COMMENT	39	07/10/2018	ISSUED FOR PUBLIC COMMENT	40	07/10/2018	ISSUED FOR PUBLIC COMMENT	41	07/10/2018	ISSUED FOR PUBLIC COMMENT	42	07/10/2018	ISSUED FOR PUBLIC COMMENT	43	07/10/2018	ISSUED FOR PUBLIC COMMENT	44	07/10/2018	ISSUED FOR PUBLIC COMMENT	45	07/10/2018	ISSUED FOR PUBLIC COMMENT	46	07/10/2018	ISSUED FOR PUBLIC COMMENT	47	07/10/2018	ISSUED FOR PUBLIC COMMENT	48	07/10/2018	ISSUED FOR PUBLIC COMMENT	49	07/10/2018	ISSUED FOR PUBLIC COMMENT	50	07/10/2018	ISSUED FOR PUBLIC COMMENT	51	07/10/2018	ISSUED FOR PUBLIC COMMENT	52	07/10/2018	ISSUED FOR PUBLIC COMMENT	53	07/10/2018	ISSUED FOR PUBLIC COMMENT	54	07/10/2018	ISSUED FOR PUBLIC COMMENT	55	07/10/2018	ISSUED FOR PUBLIC COMMENT	56	07/10/2018	ISSUED FOR PUBLIC COMMENT	57	07/10/2018	ISSUED FOR PUBLIC COMMENT	58	07/10/2018	ISSUED FOR PUBLIC COMMENT	59	07/10/2018	ISSUED FOR PUBLIC COMMENT	60	07/10/2018	ISSUED FOR PUBLIC COMMENT	61	07/10/2018	ISSUED FOR PUBLIC COMMENT	62	07/10/2018	ISSUED FOR PUBLIC COMMENT	63	07/10/2018	ISSUED FOR PUBLIC COMMENT	64	07/10/2018	ISSUED FOR PUBLIC COMMENT	65	07/10/2018	ISSUED FOR PUBLIC COMMENT	66	07/10/2018	ISSUED FOR PUBLIC COMMENT	67	07/10/2018	ISSUED FOR PUBLIC COMMENT	68	07/10/2018	ISSUED FOR PUBLIC COMMENT	69	07/10/2018	ISSUED FOR PUBLIC COMMENT	70	07/10/2018	ISSUED FOR PUBLIC COMMENT	71	07/10/2018	ISSUED FOR PUBLIC COMMENT	72	07/10/2018	ISSUED FOR PUBLIC COMMENT	73	07/10/2018	ISSUED FOR PUBLIC COMMENT	74	07/10/2018	ISSUED FOR PUBLIC COMMENT	75	07/10/2018	ISSUED FOR PUBLIC COMMENT	76	07/10/2018	ISSUED FOR PUBLIC COMMENT	77	07/10/2018	ISSUED FOR PUBLIC COMMENT	78	07/10/2018	ISSUED FOR PUBLIC COMMENT	79	07/10/2018	ISSUED FOR PUBLIC COMMENT	80	07/10/2018	ISSUED FOR PUBLIC COMMENT	81	07/10/2018	ISSUED FOR PUBLIC COMMENT	82	07/10/2018	ISSUED FOR PUBLIC COMMENT	83	07/10/2018	ISSUED FOR PUBLIC COMMENT	84	07/10/2018	ISSUED FOR PUBLIC COMMENT	85	07/10/2018	ISSUED FOR PUBLIC COMMENT	86	07/10/2018	ISSUED FOR PUBLIC COMMENT	87	07/10/2018	ISSUED FOR PUBLIC COMMENT	88	07/10/2018	ISSUED FOR PUBLIC COMMENT	89	07/10/2018	ISSUED FOR PUBLIC COMMENT	90	07/10/2018	ISSUED FOR PUBLIC COMMENT	91	07/10/2018	ISSUED FOR PUBLIC COMMENT	92	07/10/2018	ISSUED FOR PUBLIC COMMENT	93	07/10/2018	ISSUED FOR PUBLIC COMMENT	94	07/10/2018	ISSUED FOR PUBLIC COMMENT	95	07/10/2018	ISSUED FOR PUBLIC COMMENT	96	07/10/2018	ISSUED FOR PUBLIC COMMENT	97	07/10/2018	ISSUED FOR PUBLIC COMMENT	98	07/10/2018	ISSUED FOR PUBLIC COMMENT	99	07/10/2018	ISSUED FOR PUBLIC COMMENT	100	07/10/2018	ISSUED FOR PUBLIC COMMENT
					NO.	DATE	DESCRIPTION																																																																																																																																																																																																																																																																																																													
1	07/10/2018	ISSUED FOR PUBLIC COMMENT																																																																																																																																																																																																																																																																																																																		
2	07/10/2018	ISSUED FOR PUBLIC COMMENT																																																																																																																																																																																																																																																																																																																		
3	07/10/2018	ISSUED FOR PUBLIC COMMENT																																																																																																																																																																																																																																																																																																																		
4	07/10/2018	ISSUED FOR PUBLIC COMMENT																																																																																																																																																																																																																																																																																																																		
5	07/10/2018	ISSUED FOR PUBLIC COMMENT																																																																																																																																																																																																																																																																																																																		
6	07/10/2018	ISSUED FOR PUBLIC COMMENT																																																																																																																																																																																																																																																																																																																		
7	07/10/2018	ISSUED FOR PUBLIC COMMENT																																																																																																																																																																																																																																																																																																																		
8	07/10/2018	ISSUED FOR PUBLIC COMMENT																																																																																																																																																																																																																																																																																																																		
9	07/10/2018	ISSUED FOR PUBLIC COMMENT																																																																																																																																																																																																																																																																																																																		
10	07/10/2018	ISSUED FOR PUBLIC COMMENT																																																																																																																																																																																																																																																																																																																		
11	07/10/2018	ISSUED FOR PUBLIC COMMENT																																																																																																																																																																																																																																																																																																																		
12	07/10/2018	ISSUED FOR PUBLIC COMMENT																																																																																																																																																																																																																																																																																																																		
13	07/10/2018	ISSUED FOR PUBLIC COMMENT																																																																																																																																																																																																																																																																																																																		
14	07/10/2018	ISSUED FOR PUBLIC COMMENT																																																																																																																																																																																																																																																																																																																		
15	07/10/2018	ISSUED FOR PUBLIC COMMENT																																																																																																																																																																																																																																																																																																																		
16	07/10/2018	ISSUED FOR PUBLIC COMMENT																																																																																																																																																																																																																																																																																																																		
17	07/10/2018	ISSUED FOR PUBLIC COMMENT																																																																																																																																																																																																																																																																																																																		
18	07/10/2018	ISSUED FOR PUBLIC COMMENT																																																																																																																																																																																																																																																																																																																		
19	07/10/2018	ISSUED FOR PUBLIC COMMENT																																																																																																																																																																																																																																																																																																																		
20	07/10/2018	ISSUED FOR PUBLIC COMMENT																																																																																																																																																																																																																																																																																																																		
21	07/10/2018	ISSUED FOR PUBLIC COMMENT																																																																																																																																																																																																																																																																																																																		
22	07/10/2018	ISSUED FOR PUBLIC COMMENT																																																																																																																																																																																																																																																																																																																		
23	07/10/2018	ISSUED FOR PUBLIC COMMENT																																																																																																																																																																																																																																																																																																																		
24	07/10/2018	ISSUED FOR PUBLIC COMMENT																																																																																																																																																																																																																																																																																																																		
25	07/10/2018	ISSUED FOR PUBLIC COMMENT																																																																																																																																																																																																																																																																																																																		
26	07/10/2018	ISSUED FOR PUBLIC COMMENT																																																																																																																																																																																																																																																																																																																		
27	07/10/2018	ISSUED FOR PUBLIC COMMENT																																																																																																																																																																																																																																																																																																																		
28	07/10/2018	ISSUED FOR PUBLIC COMMENT																																																																																																																																																																																																																																																																																																																		
29	07/10/2018	ISSUED FOR PUBLIC COMMENT																																																																																																																																																																																																																																																																																																																		
30	07/10/2018	ISSUED FOR PUBLIC COMMENT																																																																																																																																																																																																																																																																																																																		
31	07/10/2018	ISSUED FOR PUBLIC COMMENT																																																																																																																																																																																																																																																																																																																		
32	07/10/2018	ISSUED FOR PUBLIC COMMENT																																																																																																																																																																																																																																																																																																																		
33	07/10/2018	ISSUED FOR PUBLIC COMMENT																																																																																																																																																																																																																																																																																																																		
34	07/10/2018	ISSUED FOR PUBLIC COMMENT																																																																																																																																																																																																																																																																																																																		
35	07/10/2018	ISSUED FOR PUBLIC COMMENT																																																																																																																																																																																																																																																																																																																		
36	07/10/2018	ISSUED FOR PUBLIC COMMENT																																																																																																																																																																																																																																																																																																																		
37	07/10/2018	ISSUED FOR PUBLIC COMMENT																																																																																																																																																																																																																																																																																																																		
38	07/10/2018	ISSUED FOR PUBLIC COMMENT																																																																																																																																																																																																																																																																																																																		
39	07/10/2018	ISSUED FOR PUBLIC COMMENT																																																																																																																																																																																																																																																																																																																		
40	07/10/2018	ISSUED FOR PUBLIC COMMENT																																																																																																																																																																																																																																																																																																																		
41	07/10/2018	ISSUED FOR PUBLIC COMMENT																																																																																																																																																																																																																																																																																																																		
42	07/10/2018	ISSUED FOR PUBLIC COMMENT																																																																																																																																																																																																																																																																																																																		
43	07/10/2018	ISSUED FOR PUBLIC COMMENT																																																																																																																																																																																																																																																																																																																		
44	07/10/2018	ISSUED FOR PUBLIC COMMENT																																																																																																																																																																																																																																																																																																																		
45	07/10/2018	ISSUED FOR PUBLIC COMMENT																																																																																																																																																																																																																																																																																																																		
46	07/10/2018	ISSUED FOR PUBLIC COMMENT																																																																																																																																																																																																																																																																																																																		
47	07/10/2018	ISSUED FOR PUBLIC COMMENT																																																																																																																																																																																																																																																																																																																		
48	07/10/2018	ISSUED FOR PUBLIC COMMENT																																																																																																																																																																																																																																																																																																																		
49	07/10/2018	ISSUED FOR PUBLIC COMMENT																																																																																																																																																																																																																																																																																																																		
50	07/10/2018	ISSUED FOR PUBLIC COMMENT																																																																																																																																																																																																																																																																																																																		
51	07/10/2018	ISSUED FOR PUBLIC COMMENT																																																																																																																																																																																																																																																																																																																		
52	07/10/2018	ISSUED FOR PUBLIC COMMENT																																																																																																																																																																																																																																																																																																																		
53	07/10/2018	ISSUED FOR PUBLIC COMMENT																																																																																																																																																																																																																																																																																																																		
54	07/10/2018	ISSUED FOR PUBLIC COMMENT																																																																																																																																																																																																																																																																																																																		
55	07/10/2018	ISSUED FOR PUBLIC COMMENT																																																																																																																																																																																																																																																																																																																		
56	07/10/2018	ISSUED FOR PUBLIC COMMENT																																																																																																																																																																																																																																																																																																																		
57	07/10/2018	ISSUED FOR PUBLIC COMMENT																																																																																																																																																																																																																																																																																																																		
58	07/10/2018	ISSUED FOR PUBLIC COMMENT																																																																																																																																																																																																																																																																																																																		
59	07/10/2018	ISSUED FOR PUBLIC COMMENT																																																																																																																																																																																																																																																																																																																		
60	07/10/2018	ISSUED FOR PUBLIC COMMENT																																																																																																																																																																																																																																																																																																																		
61	07/10/2018	ISSUED FOR PUBLIC COMMENT																																																																																																																																																																																																																																																																																																																		
62	07/10/2018	ISSUED FOR PUBLIC COMMENT																																																																																																																																																																																																																																																																																																																		
63	07/10/2018	ISSUED FOR PUBLIC COMMENT																																																																																																																																																																																																																																																																																																																		
64	07/10/2018	ISSUED FOR PUBLIC COMMENT																																																																																																																																																																																																																																																																																																																		
65	07/10/2018	ISSUED FOR PUBLIC COMMENT																																																																																																																																																																																																																																																																																																																		
66	07/10/2018	ISSUED FOR PUBLIC COMMENT																																																																																																																																																																																																																																																																																																																		
67	07/10/2018	ISSUED FOR PUBLIC COMMENT																																																																																																																																																																																																																																																																																																																		
68	07/10/2018	ISSUED FOR PUBLIC COMMENT																																																																																																																																																																																																																																																																																																																		
69	07/10/2018	ISSUED FOR PUBLIC COMMENT																																																																																																																																																																																																																																																																																																																		
70	07/10/2018	ISSUED FOR PUBLIC COMMENT																																																																																																																																																																																																																																																																																																																		
71	07/10/2018	ISSUED FOR PUBLIC COMMENT																																																																																																																																																																																																																																																																																																																		
72	07/10/2018	ISSUED FOR PUBLIC COMMENT																																																																																																																																																																																																																																																																																																																		
73	07/10/2018	ISSUED FOR PUBLIC COMMENT																																																																																																																																																																																																																																																																																																																		
74	07/10/2018	ISSUED FOR PUBLIC COMMENT																																																																																																																																																																																																																																																																																																																		
75	07/10/2018	ISSUED FOR PUBLIC COMMENT																																																																																																																																																																																																																																																																																																																		
76	07/10/2018	ISSUED FOR PUBLIC COMMENT																																																																																																																																																																																																																																																																																																																		
77	07/10/2018	ISSUED FOR PUBLIC COMMENT																																																																																																																																																																																																																																																																																																																		
78	07/10/2018	ISSUED FOR PUBLIC COMMENT																																																																																																																																																																																																																																																																																																																		
79	07/10/2018	ISSUED FOR PUBLIC COMMENT																																																																																																																																																																																																																																																																																																																		
80	07/10/2018	ISSUED FOR PUBLIC COMMENT																																																																																																																																																																																																																																																																																																																		
81	07/10/2018	ISSUED FOR PUBLIC COMMENT																																																																																																																																																																																																																																																																																																																		
82	07/10/2018	ISSUED FOR PUBLIC COMMENT																																																																																																																																																																																																																																																																																																																		
83	07/10/2018	ISSUED FOR PUBLIC COMMENT																																																																																																																																																																																																																																																																																																																		
84	07/10/2018	ISSUED FOR PUBLIC COMMENT																																																																																																																																																																																																																																																																																																																		
85	07/10/2018	ISSUED FOR PUBLIC COMMENT																																																																																																																																																																																																																																																																																																																		
86	07/10/2018	ISSUED FOR PUBLIC COMMENT																																																																																																																																																																																																																																																																																																																		
87	07/10/2018	ISSUED FOR PUBLIC COMMENT																																																																																																																																																																																																																																																																																																																		
88	07/10/2018	ISSUED FOR PUBLIC COMMENT																																																																																																																																																																																																																																																																																																																		
89	07/10/2018	ISSUED FOR PUBLIC COMMENT																																																																																																																																																																																																																																																																																																																		
90	07/10/2018	ISSUED FOR PUBLIC COMMENT																																																																																																																																																																																																																																																																																																																		
91	07/10/2018	ISSUED FOR PUBLIC COMMENT																																																																																																																																																																																																																																																																																																																		
92	07/10/2018	ISSUED FOR PUBLIC COMMENT																																																																																																																																																																																																																																																																																																																		
93	07/10/2018	ISSUED FOR PUBLIC COMMENT																																																																																																																																																																																																																																																																																																																		
94	07/10/2018	ISSUED FOR PUBLIC COMMENT																																																																																																																																																																																																																																																																																																																		
95	07/10/2018	ISSUED FOR PUBLIC COMMENT																																																																																																																																																																																																																																																																																																																		
96	07/10/2018	ISSUED FOR PUBLIC COMMENT																																																																																																																																																																																																																																																																																																																		
97	07/10/2018	ISSUED FOR PUBLIC COMMENT																																																																																																																																																																																																																																																																																																																		
98	07/10/2018	ISSUED FOR PUBLIC COMMENT																																																																																																																																																																																																																																																																																																																		
99	07/10/2018	ISSUED FOR PUBLIC COMMENT																																																																																																																																																																																																																																																																																																																		
100	07/10/2018	ISSUED FOR PUBLIC COMMENT																																																																																																																																																																																																																																																																																																																		



ENLARGED SITE PLAN

- ISSUES**
- 1. REVISIONS TO THE 2017 1/2" X 1/4" PLAN WITH PERMITS TO THE CITY OF IRVINE, CALIFORNIA
  - 2. REVISIONS TO THE 2017 1/2" X 1/4" PLAN WITH PERMITS TO THE CITY OF IRVINE, CALIFORNIA
  - 3. REVISIONS TO THE 2017 1/2" X 1/4" PLAN WITH PERMITS TO THE CITY OF IRVINE, CALIFORNIA
  - 4. REVISIONS TO THE 2017 1/2" X 1/4" PLAN WITH PERMITS TO THE CITY OF IRVINE, CALIFORNIA
  - 5. REVISIONS TO THE 2017 1/2" X 1/4" PLAN WITH PERMITS TO THE CITY OF IRVINE, CALIFORNIA
  - 6. REVISIONS TO THE 2017 1/2" X 1/4" PLAN WITH PERMITS TO THE CITY OF IRVINE, CALIFORNIA
  - 7. REVISIONS TO THE 2017 1/2" X 1/4" PLAN WITH PERMITS TO THE CITY OF IRVINE, CALIFORNIA
  - 8. REVISIONS TO THE 2017 1/2" X 1/4" PLAN WITH PERMITS TO THE CITY OF IRVINE, CALIFORNIA
  - 9. REVISIONS TO THE 2017 1/2" X 1/4" PLAN WITH PERMITS TO THE CITY OF IRVINE, CALIFORNIA
  - 10. REVISIONS TO THE 2017 1/2" X 1/4" PLAN WITH PERMITS TO THE CITY OF IRVINE, CALIFORNIA
  - 11. REVISIONS TO THE 2017 1/2" X 1/4" PLAN WITH PERMITS TO THE CITY OF IRVINE, CALIFORNIA
  - 12. REVISIONS TO THE 2017 1/2" X 1/4" PLAN WITH PERMITS TO THE CITY OF IRVINE, CALIFORNIA
  - 13. REVISIONS TO THE 2017 1/2" X 1/4" PLAN WITH PERMITS TO THE CITY OF IRVINE, CALIFORNIA
  - 14. REVISIONS TO THE 2017 1/2" X 1/4" PLAN WITH PERMITS TO THE CITY OF IRVINE, CALIFORNIA
  - 15. REVISIONS TO THE 2017 1/2" X 1/4" PLAN WITH PERMITS TO THE CITY OF IRVINE, CALIFORNIA
  - 16. REVISIONS TO THE 2017 1/2" X 1/4" PLAN WITH PERMITS TO THE CITY OF IRVINE, CALIFORNIA
  - 17. REVISIONS TO THE 2017 1/2" X 1/4" PLAN WITH PERMITS TO THE CITY OF IRVINE, CALIFORNIA
  - 18. REVISIONS TO THE 2017 1/2" X 1/4" PLAN WITH PERMITS TO THE CITY OF IRVINE, CALIFORNIA
  - 19. REVISIONS TO THE 2017 1/2" X 1/4" PLAN WITH PERMITS TO THE CITY OF IRVINE, CALIFORNIA
  - 20. REVISIONS TO THE 2017 1/2" X 1/4" PLAN WITH PERMITS TO THE CITY OF IRVINE, CALIFORNIA

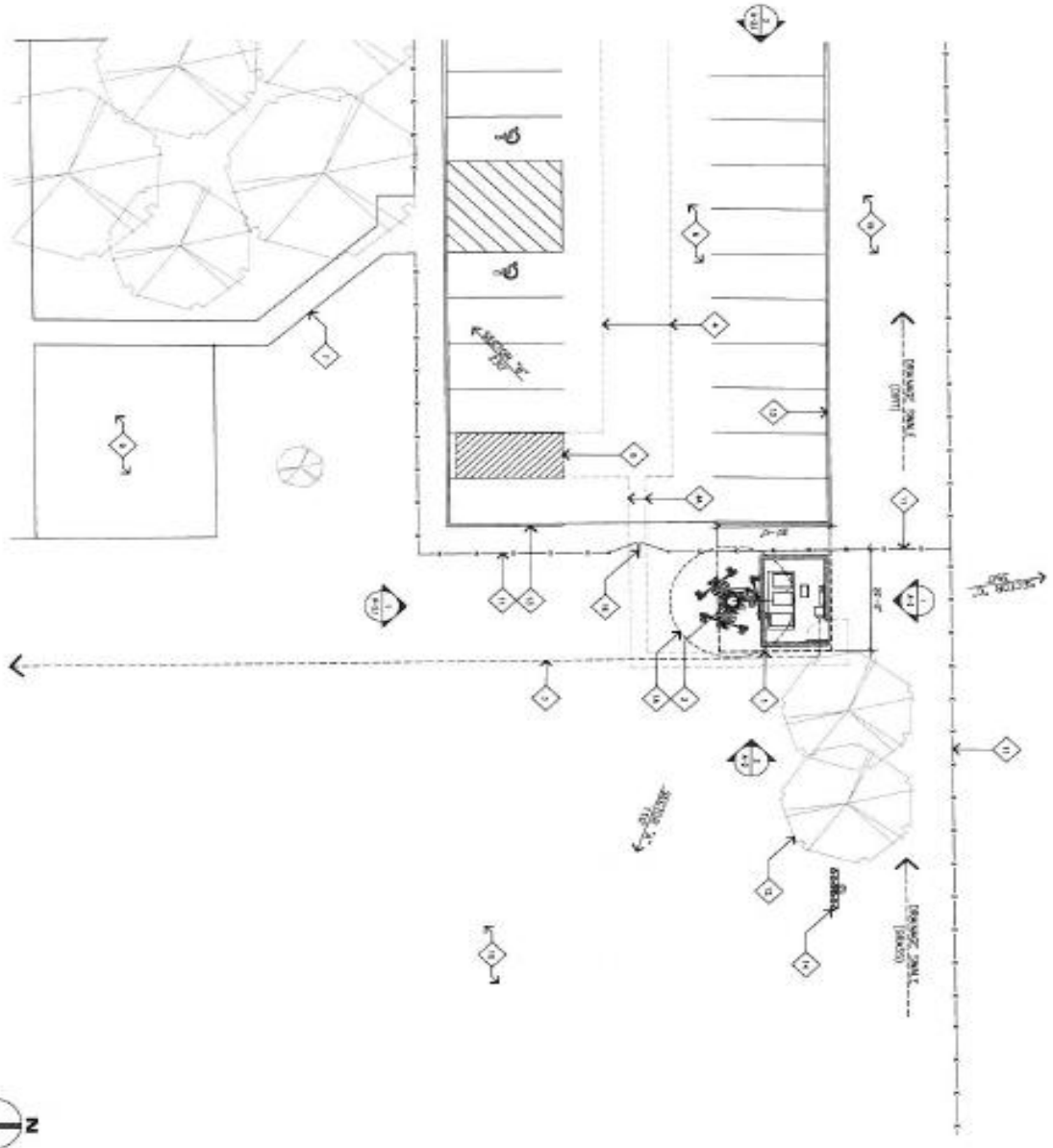

SCALE: 1"=10'

0 5 10'

1

N

<p><b>A-1.1</b></p> <p>SHEET TITLE ENLARGED SITE PLAN</p>	<p><b>CHOLA</b> 21860 TUSSING RANCH RD APPLE VALLEY, CALIFORNIA 92308</p>		<p><b>verizon</b></p> <p>1980 SAND CANYON AVENUE, 01 IRVINE, CA 92618</p>	<p><b>IRVINE</b> CITY ENGINEER</p>	<p><b>ISSUE STATUS</b></p>	
					<p>DATE</p> <p>DESCRIPTION</p> <p>BY</p> <p>APPROVED BY</p> <p>STATUS</p>	<p>DATE</p> <p>DESCRIPTION</p> <p>BY</p> <p>APPROVED BY</p> <p>STATUS</p>

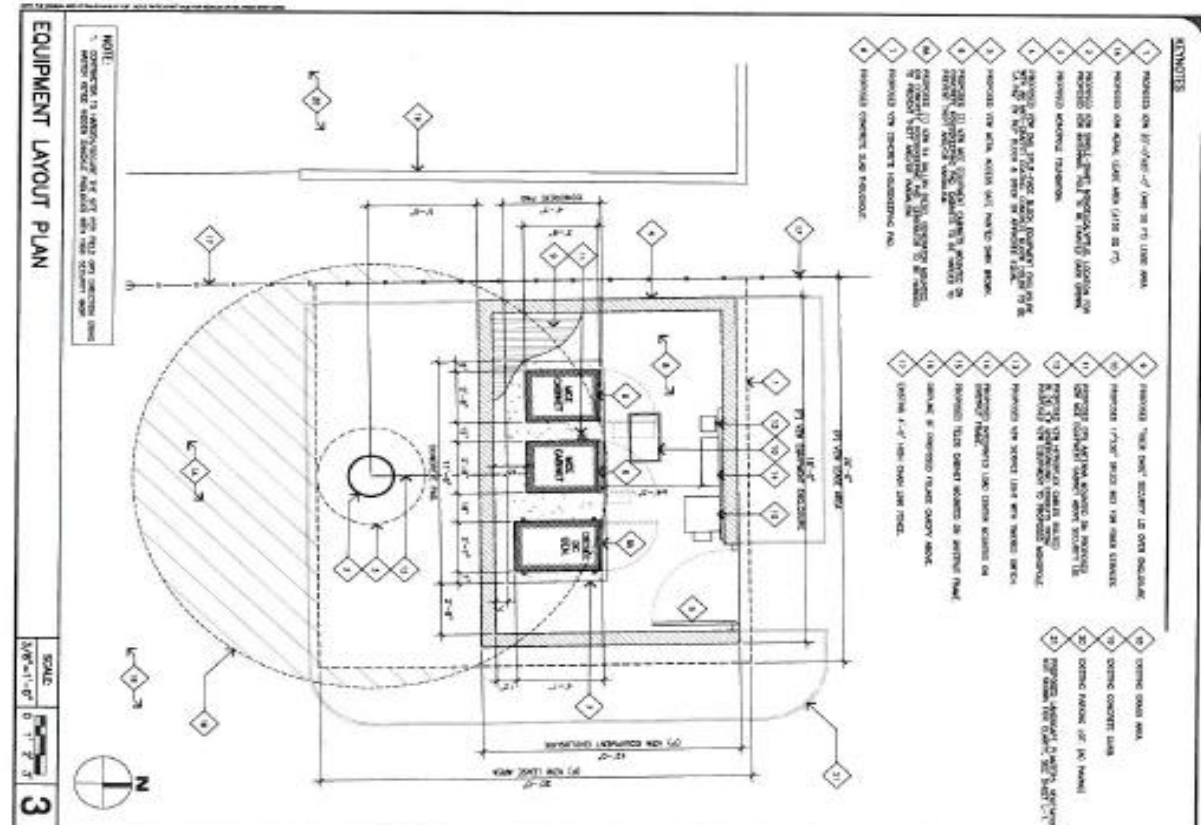

NOTE:  
 1. REFER TO LABORATORY 24 OF THE THE ENVIRONMENTAL AND ENERGY CENTER PROJECT FOR THE LOCATION OF THE EQUIPMENT ROOM.

EQUIPMENT LAYOUT PLAN

SCALE: 1/8" = 1'-0"  
 3

- REVISIONS**
- 1. PROPOSED ON 07/10/18 AT 1:00 PM
  - 2. PROPOSED ON 08/01/18 AT 1:00 PM
  - 3. PROPOSED ON 08/01/18 AT 1:00 PM
  - 4. PROPOSED ON 08/01/18 AT 1:00 PM
  - 5. PROPOSED ON 08/01/18 AT 1:00 PM
  - 6. PROPOSED ON 08/01/18 AT 1:00 PM
  - 7. PROPOSED ON 08/01/18 AT 1:00 PM
  - 8. PROPOSED ON 08/01/18 AT 1:00 PM
  - 9. PROPOSED ON 08/01/18 AT 1:00 PM
  - 10. PROPOSED ON 08/01/18 AT 1:00 PM
  - 11. PROPOSED ON 08/01/18 AT 1:00 PM
  - 12. PROPOSED ON 08/01/18 AT 1:00 PM
  - 13. PROPOSED ON 08/01/18 AT 1:00 PM
  - 14. PROPOSED ON 08/01/18 AT 1:00 PM
  - 15. PROPOSED ON 08/01/18 AT 1:00 PM
  - 16. PROPOSED ON 08/01/18 AT 1:00 PM
  - 17. PROPOSED ON 08/01/18 AT 1:00 PM
  - 18. PROPOSED ON 08/01/18 AT 1:00 PM
  - 19. PROPOSED ON 08/01/18 AT 1:00 PM
  - 20. PROPOSED ON 08/01/18 AT 1:00 PM
  - 21. PROPOSED ON 08/01/18 AT 1:00 PM
  - 22. PROPOSED ON 08/01/18 AT 1:00 PM
  - 23. PROPOSED ON 08/01/18 AT 1:00 PM
  - 24. PROPOSED ON 08/01/18 AT 1:00 PM
  - 25. PROPOSED ON 08/01/18 AT 1:00 PM
  - 26. PROPOSED ON 08/01/18 AT 1:00 PM
  - 27. PROPOSED ON 08/01/18 AT 1:00 PM
  - 28. PROPOSED ON 08/01/18 AT 1:00 PM
  - 29. PROPOSED ON 08/01/18 AT 1:00 PM
  - 30. PROPOSED ON 08/01/18 AT 1:00 PM

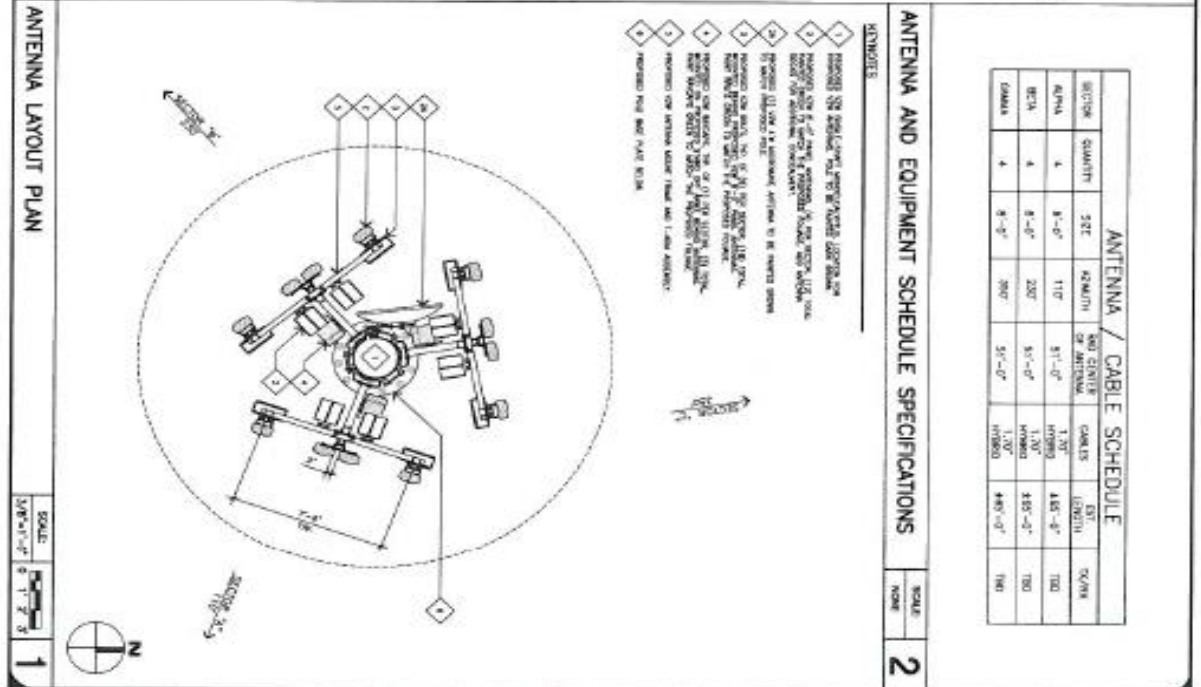

NOTE:  
 1. REFER TO LABORATORY 24 OF THE THE ENVIRONMENTAL AND ENERGY CENTER PROJECT FOR THE LOCATION OF THE ANTENNA ARRAY.

ANTENNA LAYOUT PLAN

SCALE: 1/8" = 1'-0"  
 1

**REVISIONS**

- 1. PROPOSED ON 07/10/18 AT 1:00 PM
- 2. PROPOSED ON 08/01/18 AT 1:00 PM
- 3. PROPOSED ON 08/01/18 AT 1:00 PM
- 4. PROPOSED ON 08/01/18 AT 1:00 PM
- 5. PROPOSED ON 08/01/18 AT 1:00 PM
- 6. PROPOSED ON 08/01/18 AT 1:00 PM
- 7. PROPOSED ON 08/01/18 AT 1:00 PM
- 8. PROPOSED ON 08/01/18 AT 1:00 PM
- 9. PROPOSED ON 08/01/18 AT 1:00 PM
- 10. PROPOSED ON 08/01/18 AT 1:00 PM
- 11. PROPOSED ON 08/01/18 AT 1:00 PM
- 12. PROPOSED ON 08/01/18 AT 1:00 PM
- 13. PROPOSED ON 08/01/18 AT 1:00 PM
- 14. PROPOSED ON 08/01/18 AT 1:00 PM
- 15. PROPOSED ON 08/01/18 AT 1:00 PM
- 16. PROPOSED ON 08/01/18 AT 1:00 PM
- 17. PROPOSED ON 08/01/18 AT 1:00 PM
- 18. PROPOSED ON 08/01/18 AT 1:00 PM
- 19. PROPOSED ON 08/01/18 AT 1:00 PM
- 20. PROPOSED ON 08/01/18 AT 1:00 PM
- 21. PROPOSED ON 08/01/18 AT 1:00 PM
- 22. PROPOSED ON 08/01/18 AT 1:00 PM
- 23. PROPOSED ON 08/01/18 AT 1:00 PM
- 24. PROPOSED ON 08/01/18 AT 1:00 PM
- 25. PROPOSED ON 08/01/18 AT 1:00 PM
- 26. PROPOSED ON 08/01/18 AT 1:00 PM
- 27. PROPOSED ON 08/01/18 AT 1:00 PM
- 28. PROPOSED ON 08/01/18 AT 1:00 PM
- 29. PROPOSED ON 08/01/18 AT 1:00 PM
- 30. PROPOSED ON 08/01/18 AT 1:00 PM

**ANTENNA AND EQUIPMENT SCHEDULE SPECIFICATIONS**

SECTION	QUANTITY	SIZE	QUALITY	ANTENNA	ANTENNA CENTER OF ANTENNA	CABLES	EST. LENGTH	SCALE
ALPHA	4	8'-0"	110'	51'-0"	1.10'	4.85'-0"	100	
BETA	4	8'-0"	200'	51'-0"	1.10'	4.85'-0"	100	
DELTA	4	8'-0"	200'	51'-0"	1.10'	4.85'-0"	100	

SCALE: NONE  
 2

**CHOLA**  
 21800 TUSSING RANCH RD  
 APPLE VALLEY, CALIFORNIA  
 92308

1585 SAND CANYON AVENUE, D1  
 IRVINE, CA 92618

**ISSUE STATUS**

NO.	DATE	DESCRIPTION	BY
1	07/10/18	ISSUED FOR PERMITTING	...
2	08/01/18	...	...
3	08/01/18	...	...
4	08/01/18	...	...
5	08/01/18	...	...
6	08/01/18	...	...
7	08/01/18	...	...
8	08/01/18	...	...
9	08/01/18	...	...
10	08/01/18	...	...
11	08/01/18	...	...
12	08/01/18	...	...
13	08/01/18	...	...
14	08/01/18	...	...
15	08/01/18	...	...
16	08/01/18	...	...
17	08/01/18	...	...
18	08/01/18	...	...
19	08/01/18	...	...
20	08/01/18	...	...

**A-1.2**

ANTENNA PLAN,  
 EQUIPMENT PLAN,  
 ANTENNA SCHEDULE

- REVISIONS**
- 1. REVISIONS TO THE EAST ELEVATION TO ADD THE TREE TO THE EAST SIDE OF THE HOUSE.
  - 2. REVISIONS TO THE EAST ELEVATION TO ADD THE TREE TO THE EAST SIDE OF THE HOUSE.
  - 3. REVISIONS TO THE EAST ELEVATION TO ADD THE TREE TO THE EAST SIDE OF THE HOUSE.
  - 4. REVISIONS TO THE EAST ELEVATION TO ADD THE TREE TO THE EAST SIDE OF THE HOUSE.
  - 5. REVISIONS TO THE EAST ELEVATION TO ADD THE TREE TO THE EAST SIDE OF THE HOUSE.
  - 6. REVISIONS TO THE EAST ELEVATION TO ADD THE TREE TO THE EAST SIDE OF THE HOUSE.
  - 7. REVISIONS TO THE EAST ELEVATION TO ADD THE TREE TO THE EAST SIDE OF THE HOUSE.
  - 8. REVISIONS TO THE EAST ELEVATION TO ADD THE TREE TO THE EAST SIDE OF THE HOUSE.
  - 9. REVISIONS TO THE EAST ELEVATION TO ADD THE TREE TO THE EAST SIDE OF THE HOUSE.
  - 10. REVISIONS TO THE EAST ELEVATION TO ADD THE TREE TO THE EAST SIDE OF THE HOUSE.

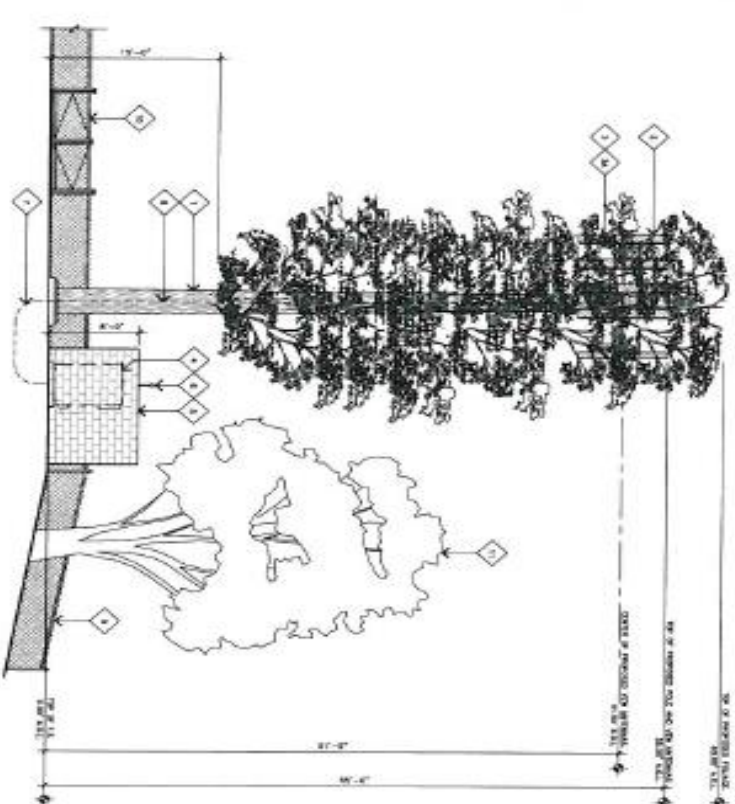

EAST ELEVATION

SCALE: 1/4" = 1'-0"  
0 3 6  
**2**

- REVISIONS**
- 1. REVISIONS TO THE NORTH ELEVATION TO ADD THE TREE TO THE NORTH SIDE OF THE HOUSE.
  - 2. REVISIONS TO THE NORTH ELEVATION TO ADD THE TREE TO THE NORTH SIDE OF THE HOUSE.
  - 3. REVISIONS TO THE NORTH ELEVATION TO ADD THE TREE TO THE NORTH SIDE OF THE HOUSE.
  - 4. REVISIONS TO THE NORTH ELEVATION TO ADD THE TREE TO THE NORTH SIDE OF THE HOUSE.
  - 5. REVISIONS TO THE NORTH ELEVATION TO ADD THE TREE TO THE NORTH SIDE OF THE HOUSE.
  - 6. REVISIONS TO THE NORTH ELEVATION TO ADD THE TREE TO THE NORTH SIDE OF THE HOUSE.
  - 7. REVISIONS TO THE NORTH ELEVATION TO ADD THE TREE TO THE NORTH SIDE OF THE HOUSE.
  - 8. REVISIONS TO THE NORTH ELEVATION TO ADD THE TREE TO THE NORTH SIDE OF THE HOUSE.
  - 9. REVISIONS TO THE NORTH ELEVATION TO ADD THE TREE TO THE NORTH SIDE OF THE HOUSE.
  - 10. REVISIONS TO THE NORTH ELEVATION TO ADD THE TREE TO THE NORTH SIDE OF THE HOUSE.

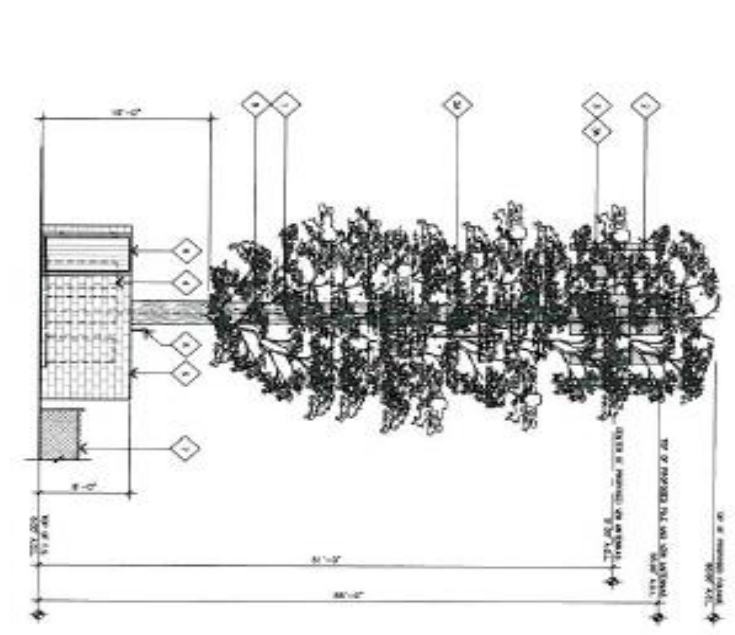

NORTH ELEVATION

SCALE: 1/4" = 1'-0"  
0 3 6  
**1**

**ISSUE STATUS**

NO.	DATE	DESCRIPTION
1	07/10/2018	ISSUE FOR REVIEW
2	07/10/2018	ISSUE FOR REVIEW
3	07/10/2018	ISSUE FOR REVIEW
4	07/10/2018	ISSUE FOR REVIEW
5	07/10/2018	ISSUE FOR REVIEW
6	07/10/2018	ISSUE FOR REVIEW
7	07/10/2018	ISSUE FOR REVIEW
8	07/10/2018	ISSUE FOR REVIEW
9	07/10/2018	ISSUE FOR REVIEW
10	07/10/2018	ISSUE FOR REVIEW

**JULIE M. BROWN**  
ARCHITECT  
121 BAYVIEW DRIVE, SUITE 100  
APPLE VALLEY, CA 92308  
TEL: 951-941-1111  
WWW.JULIEBROWNARCHITECT.COM

**PERMITTING INFORMATION**  
ALL PERMITTING INFORMATION IS SUBJECT TO THE LOCAL AGENCIES' REQUIREMENTS.  
FOR MORE INFORMATION, CONTACT THE LOCAL AGENCIES.

**verizon**  
12000 SAND CANYON AVENUE, G1  
IRVINE, CA 92618



**CHOLA**  
21860 TUSSING RANCH RD  
APPLE VALLEY, CALIFORNIA  
92308

SHEET TITLE  
**ELEVATIONS**

**A-2**



# Verizon Chola

21860 Tussing Ranch Rd. - Apple Valley, CA 92308

## VICINITY



Verizon Wireless  
15505 Sand Canyon Ave.  
Irvine, CA 92618



J5 Infrastructure Partners  
2030 Main Street, Suite 200  
Irvine, CA 92614

# Verizon Chola

21860 Tussing Ranch Rd. - Apple Valley, CA 92308

EXISTING

WEST LOOKING EAST



PROPOSED



Verizon Wireless  
15505 Sand Canyon Ave.  
Irvine, CA 92618



J5 Infrastructure Partners  
2030 Main Street, Suite 200  
Irvine, CA 92614

Sheet No.

1

# Verizon Chola

21860 Tussing Ranch Rd. - Apple Valley, CA 92308

EXISTING

SOUTH LOOKING NORTH



PROPOSED

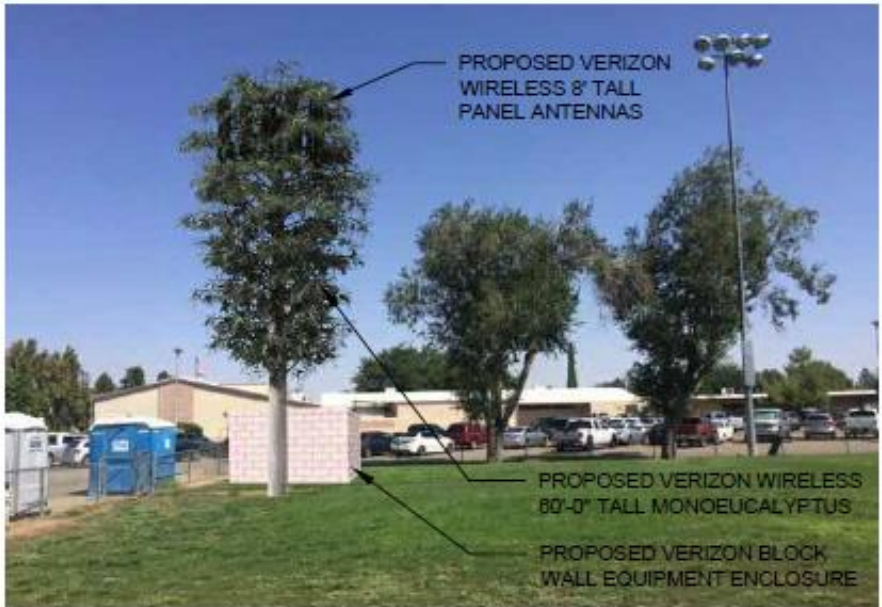

Verizon Wireless  
15505 Sand Canyon Ave.  
Irvine, CA 92618



J5 Infrastructure Partners  
2030 Main Street, Suite 200  
Irvine, CA 92614

Sheet No.

2

# Verizon Chola

21860 Tussing Ranch Rd. - Apple Valley, CA 92308

EXISTING

SOUTHEAST LOOKING NORTHWEST



PROPOSED



Verizon Wireless  
15505 Sand Canyon Ave.  
Irvine, CA 92618



J5 Infrastructure Partners  
2030 Main Street, Suite 200  
Irvine, CA 92614

Sheet No.

3